

[Link To:](#)

[Baird Municipal Bond Funds Prospectus](#)

[Baird Short-Term Municipal Bond Fund Summary Prospectus](#)

[Baird Core Intermediate Municipal Bond Fund Summary Prospectus](#)



**BAIRD FUNDS, INC.**  
**Statement of Additional Information**

Baird Short-Term Municipal Bond Fund  
(Institutional Class: BTMIX)  
(Investor Class: BTMSX)  
Baird Core Intermediate Municipal Bond Fund  
(Institutional Class: BMNIX)  
(Investor Class: BMNSX)

August 31, 2015

This Statement of Additional Information (“SAI”) is not a prospectus and should be read in conjunction with the Prospectus dated August 31, 2015 of the Baird Short-Term Municipal Bond Fund and the Baird Core Intermediate Municipal Bond Fund (each a “Fund” and together the “Funds”). Each Fund is a series of Baird Funds, Inc. (the “Company”). This SAI contains additional information about principal strategies and risks already described in the Prospectus, as well as descriptions of non-principal strategies not described in the Prospectus. Copies of the Funds’ Prospectus may be obtained, free of charge by writing the Funds at 615 East Michigan Street, P.O. Box 701, Milwaukee, Wisconsin 53201-0701, by calling (toll-free) 1-866-44BAIRD, or on the Funds’ website at [www.bairdfunds.com](http://www.bairdfunds.com). You should read this SAI together with the Prospectus and retain it for further reference.

**TABLE OF CONTENTS**

	<u>Page</u>
BAIRD FUNDS, INC. ....	3
INVESTMENT STRATEGIES AND RISKS .....	3
INVESTMENT OBJECTIVES AND LIMITATIONS .....	17
NET ASSET VALUE .....	20
ADDITIONAL PURCHASE AND REDEMPTION INFORMATION.....	21
DESCRIPTION OF SHARES .....	24
ADDITIONAL INFORMATION CONCERNING TAXES.....	24
MANAGEMENT OF THE COMPANY .....	26
CONTROL PERSONS AND PRINCIPAL SHAREHOLDERS .....	33
PORTFOLIO TRANSACTIONS .....	33
INVESTMENT ADVISORY AND OTHER SERVICES.....	35
PORTFOLIO MANAGERS .....	39
DISTRIBUTOR .....	40
DISTRIBUTION PLAN .....	40
PORTFOLIO HOLDINGS DISCLOSURE POLICY .....	42
ANTI-MONEY LAUNDERING PROGRAM .....	43
INDEPENDENT REGISTERED PUBLIC ACCOUNTING FIRM AND FINANCIAL STATEMENTS	43
COUNSEL .....	43
PERFORMANCE .....	44
APPENDIX A - RATINGS DEFINITIONS .....	A-1

## **BAIRD FUNDS, INC.**

The Company is an open-end, diversified management investment company. Each Fund is a series of common stock of the Company, a Wisconsin corporation that was incorporated on June 9, 2000. The Company is authorized to issue shares of common stock in series and classes. Each series of the Company is currently divided into two classes, an Investor Class and an Institutional Class. The Company also offers six other fixed income funds and three equity funds that are described in separate Prospectuses and SAIs.

### **INVESTMENT STRATEGIES AND RISKS**

Note on Percentage Limitations. Whenever an investment objective, policy or strategy of a Fund set forth in the Fund's Prospectus or this SAI states a maximum (or minimum) percentage of the Fund's assets that may be invested in any type of debt obligation or asset class, the percentage is determined immediately after the Fund's acquisition of that investment, except with respect to percentage limitations on temporary borrowing and illiquid investments. Accordingly, any later increase or decrease resulting from a change in the market value of a debt obligation or in the Fund's assets (e.g., due to net sales or redemptions of Fund shares) will not cause the Fund to violate a percentage limitation. As a result, due to market fluctuations, cash inflows or outflows or other factors, the Fund may exceed such percentage limitations from time to time.

Ratings. The ratings of Standard & Poor's ("S&P"), Moody's Investors Service, Inc. ("Moody's"), Fitch Ratings ("Fitch") and other nationally recognized statistical rating organizations represent their opinions as to the quality of debt obligations. Investment grade debt obligations are obligations that are of medium to high-quality and are rated in any of the four highest long-term rating categories by at least one nationally recognized statistical rating organization (e.g., BBB- or above by S&P, BBB- or above by Fitch or Baa3 or above by Moody's). It should be emphasized, however, that ratings are general and are not absolute standards of quality, and debt obligations with the same maturity, interest rate and rating may have different yields while debt obligations of the same maturity and interest rate with different ratings may have the same yield.

The payment of principal and interest on most debt obligations purchased by a Fund will depend upon the ability of the issuers to meet their obligations. An issuer's obligations under its debt obligations are subject to the provisions of bankruptcy, insolvency, and other laws affecting the rights and remedies of creditors, such as the Federal Bankruptcy Code, and laws, if any, which may be enacted by federal or state legislatures extending the time for payment of principal or interest, or both, or imposing other constraints upon enforcement of such obligations. The power or ability of an issuer to meet its obligations for the payment of interest on, and principal of, its debt obligations may be materially adversely affected by litigation or other conditions.

Subsequent to its purchase by a Fund, a rated debt obligation may cease to be rated or its rating may be reduced below the minimum rating required for purchase by the Fund. Robert W. Baird & Co. Incorporated (the "Advisor") will consider such an event in determining whether a Fund should continue to hold the debt obligation.

Money Market Instruments. The Funds may invest from time to time in "money market instruments," a term that includes, among other things, U.S. government obligations, repurchase agreements, cash, bank obligations, commercial paper, variable amount master demand notes and corporate bonds with remaining maturities of 13 months or less.

Bank obligations include bankers' acceptances, negotiable certificates of deposit and non-negotiable time deposits, including U.S. dollar-denominated instruments issued or supported by the credit of U.S. or foreign

banks or savings institutions. Although the Funds will invest in money market obligations of foreign banks or foreign branches of U.S. banks only where the Advisor determines the instrument to present minimal credit risks, such investments may nevertheless entail risks that are different from those of investments in domestic obligations of U.S. banks due to differences in political, regulatory and economic systems and conditions. All investments in bank obligations are limited to the obligations of financial institutions having more than \$1 billion in total assets at the time of purchase, and investments by a Fund in the obligations of foreign banks and foreign branches of U.S. banks will not exceed 20% of the Fund's net assets at the time of purchase. Each Fund may also make interest-bearing savings deposits in commercial and savings banks in amounts not in excess of 5% of its net assets.

Investments by a Fund in commercial paper will consist of issues rated at the time A-1 by S&P, Prime-1 by Moody's or a similar short-term credit rating by another nationally recognized statistical rating organization. In addition, the Funds may acquire unrated commercial paper and corporate bonds that are determined by the Advisor at the time of purchase to be of comparable quality to rated instruments that may be acquired by a Fund as previously described.

The Funds may also purchase variable amount master demand notes which are unsecured instruments that permit the indebtedness thereunder to vary and provide for periodic adjustments in the interest rate. Although the notes are not normally traded and there may be no secondary market in the notes, a Fund may demand payment of the principal of the instrument at any time. The notes are not typically rated by credit rating agencies, but issuers of variable amount master demand notes must satisfy the same criteria as set forth above for issuers of commercial paper. If an issuer of a variable amount master demand note defaulted on its payment obligation, a Fund might be unable to dispose of the note because of the absence of a secondary market and might, for this or other reasons, suffer a loss to the extent of the default. The Funds invest in variable amount master demand notes only when the Advisor deems the investment to involve minimal credit risk.

Repurchase Agreements. As a non-principal investment strategy, the Funds may agree to purchase securities from financial institutions subject to the seller's agreement to repurchase them at an agreed upon time and price ("repurchase agreements"). During the term of the repurchase agreement, the Advisor will continue to monitor the creditworthiness of the seller and will require the seller to maintain the value of the securities subject to the repurchase agreement at not less than 102% of the repurchase price. Default or bankruptcy of the seller would, however, expose a Fund to possible loss because of adverse market action or delay in connection with the disposition of the underlying securities. The securities held subject to a repurchase agreement may have stated maturities exceeding one year, provided the repurchase agreement itself matures in less than one year.

The repurchase price under the repurchase agreements generally equals the price paid by a Fund plus interest negotiated on the basis of current short-term rates (which may be more or less than the rate on the securities underlying the repurchase agreement). Securities subject to repurchase agreements will be held by the Funds' custodian or in the Federal Reserve/Treasury book-entry system or other authorized securities depository. Repurchase agreements are considered to be loans under the 1940 Act.

Investment Companies. As a non-principal investment strategy, the Funds may invest in securities issued by other investment companies, including exchange-traded funds, closed-end funds, and other affiliated Baird Funds, to the extent permitted by the 1940 Act and the rules and regulations thereunder and any exemptive relief therefrom. Under the 1940 Act, the Fund generally may not acquire (1) more than 3% of the voting stock of any one investment company, (2) securities of an investment company with a value in excess of 5% of the Fund's total assets or (3) securities of all investment companies with a value in excess of 10% of the Fund's total assets. Investments in money market funds as well as investments in affiliated Baird Funds are generally exempt from these limitations. These other investment companies will generally

consist of money market mutual funds as well as mutual funds and exchange-traded funds that primarily invest in fixed income securities or are related to a bond-related index. As a shareholder of another investment company, a Fund would bear, along with other shareholders, a pro-rata portion of the other investment company's expenses, including advisory fees, and such fees and other expenses will be borne indirectly by the Fund's shareholders. These expenses would be in addition to the advisory and other expenses that a Fund bears directly in connection with its own operations. With respect to investments by the Funds in affiliated Baird Funds, the Advisor may receive a management fee from both the investing Fund and the underlying Baird Fund.

U.S. Government Obligations. As a non-principal investment strategy, the Funds may invest in a variety of U.S. Treasury obligations including bonds, notes and bills that mainly differ only in their interest rates, maturities and time of issuance. The Funds may also invest in other debt obligations issued, sponsored or guaranteed by the U.S. government, its agencies and instrumentalities, such as obligations of Federal Home Loan Banks, Federal Farm Credit Banks, Federal Land Banks, the Federal Housing Administration, Farmers Home Administration, Export-Import Bank of the United States, Small Business Administration, Government National Mortgage Association ("GNMA"), Federal National Mortgage Association ("FNMA"), General Services Administration, Central Bank for Cooperatives, Federal Home Loan Mortgage Corporation ("FHLMC"), Federal Intermediate Credit Banks, Maritime Administration, and Resolution Trust Corp. In September 2008, at the direction of the Federal Housing Finance Agency ("FHFA"), an independent regulator, FNMA and FHLMC were placed into conservatorship. See "Mortgage-Backed Debt Obligations" below.

Bank Obligations. For purposes of the Funds' investment policies with respect to bank obligations, the assets of a bank or savings institution will be deemed to include the assets of its domestic and foreign branches. A Fund's investments in the obligations of foreign branches of U.S. banks and of foreign banks may subject the Fund to investment risks that are different in some respects from those of investments in obligations of U.S. domestic issuers. Such risks include future political and economic developments, the possible imposition of withholding taxes on interest income, possible seizure or nationalization of foreign deposits, the possible establishment of exchange controls or the adoption of other foreign governmental restrictions which might adversely affect the payment of principal and interest of such obligations. In addition, foreign branches of U.S. banks and foreign banks may be subject to less stringent reserve requirements and to different accounting, auditing, reporting and record keeping standards than those applicable to domestic branches of U.S. banks.

Illiquid and Restricted Obligations. As a non-principal investment strategy, the Funds may invest up to 15% of their net assets in debt obligations that are illiquid at the time of purchase. While these holdings may offer more potential for growth, they may present a higher degree of business and financial risk, which can result in substantial losses. The Funds may have difficulty valuing these holdings and may be unable to sell these holdings at the time or price desired. In the event a Fund's holdings should exceed 15% of its net assets, the Fund will not purchase additional illiquid debt obligations and will take other appropriate steps to reduce the percentage of illiquid debt obligations, such as disposing of illiquid assets.

Restricted securities may include Rule 144A securities as well as Section 4(2) commercial paper. Rule 144A securities are restricted securities that are eligible for resale pursuant to Rule 144A under the Securities Act of 1933, as amended (the "1933 Act"). Section 4(2) commercial paper is a short-term debt instrument issued by a corporation to institutional and other accredited investors in a transaction or series of transactions exempt from registration pursuant to Section 4(2) of the 1933 Act. A Fund may treat a Rule 144A security or Section 4(2) commercial paper as liquid if determined by the Advisor to be so under procedures adopted by the Company's Board of Directors (the "Board").

Borrowings and Reverse Repurchase Agreements. As a non-principal investment strategy, the Funds may borrow money to the extent allowed (as described below) to meet shareholder redemptions from banks or through reverse repurchase agreements. Any borrowing by the Fund may not remain outstanding for more than 15 business days and may not be made for leveraging purposes. If the debt obligations held by a Fund should decline in value while borrowings are outstanding, the Fund's net asset value will decline in value by proportionately more than the decline in value suffered by the Fund's debt obligations. As a result, a Fund's net asset value may be subject to greater fluctuation until the borrowing is paid off. The Funds have established a line of credit with U.S. Bank N.A., their custodian bank, by which each Fund may borrow money for temporary or emergency purposes. Each Fund may pledge assets to secure bank borrowings, which are limited to 33⅓% of the Fund's total assets. An unsecured line of credit is available to the Funds for any period during which U.S. Bank is an affiliate of the Funds.

Reverse repurchase agreements are considered to be borrowings under the 1940 Act. At the time a Fund enters into a reverse repurchase agreement (an agreement under which the Fund sells portfolio debt obligations and agrees to repurchase them at an agreed-upon date and price), the Fund will place in a segregated custodial account U.S. government debt obligations or other liquid debt obligations having a value equal to or greater than the repurchase price (including accrued interest), and will subsequently monitor the account to ensure that such value is maintained. Reverse repurchase agreements involve the risks that the interest income earned by a Fund (from the investment of the proceeds) will be less than the interest expense of the transaction, that the market value of the debt obligations sold by the Fund may decline below the price of the debt obligations it is obligated to repurchase and that the debt obligations may not be returned to the Fund.

Mortgage-Backed Debt Obligations. As a non-principal investment strategy, the Funds may invest in fixed-income obligations backed by a pool of mortgages. As described below under "Municipal Obligations –Revenue Bonds," the Funds may also invest in housing bonds, which are issued to finance multi-family housing projects or single-family home mortgages and are secured by the payment of the underlying mortgage loans, as part of their principal strategy. Mortgage-backed debt obligations are issued both by U.S. government agencies, including GNMA, FNMA and FHLMC and by private entities. The payment of interest and principal on debt obligations issued by U.S. government agencies is guaranteed by the full faith and credit of the U.S. government (in the case of GNMA securities) or the issuer (in the case of FNMA and FHLMC securities). However, the guarantees do not apply to the market prices and yields of these debt obligations, which vary with changes in interest rates. Mortgage-backed debt obligations issued by private entities are structured similarly to mortgage-backed debt obligations issued by GNMA, FNMA and FHLMC. These debt obligations and the underlying mortgages are not guaranteed by government agencies. However, these debt obligations generally are structured with one or more types of credit enhancement by a third party. Mortgage-backed debt obligations permit borrowers to prepay their underlying mortgages. Prepayments by borrowers on underlying obligations can alter the effective maturity of these instruments. These debt obligations represent interests in pools of assets in which periodic payments of interest and/or principal on the debt obligations are made, thus, in effect passing through periodic payments made by the individual borrowers on the assets that underlie the debt obligations, net of any fees paid to the issuer or guarantor of the debt obligations.

The average life of these debt obligations varies with the maturities and the prepayment experience of the underlying instruments. The average life of a mortgage-backed instrument may be substantially less than the original maturity of the mortgages underlying the debt obligations as the result of scheduled principal payments and mortgage prepayments. The rate of such mortgage prepayments, and hence the life of the debt obligation, will be a function of current market rates and current conditions in the relevant housing and commercial markets. In periods of falling interest rates, the rate of mortgage prepayments tends to increase. During such periods, the reinvestment of prepayment proceeds by a Fund will generally be at lower rates than the rates that were carried by the obligations that have been prepaid. As a result, the

relationship between mortgage prepayments and interest rates may give some high-yielding mortgage-related debt obligations less potential for growth in value than non-callable bonds with comparable maturities. In calculating the average weighted maturity of a Fund, the maturity of asset-backed debt obligations will be based on estimates of average life. There can be no assurance that these estimates will be accurate.

In September 2008, at the direction of the U.S. Department of the Treasury, FNMA and FHLMC were placed into conservatorship under the FHFA. The U.S. government also took steps to provide additional financial support to FNMA and FHLMC. No assurance can be given that the U.S. Treasury initiatives with respect to FNMA and FHLMC will be successful.

Bond Index. In an effort to make a Fund's duration and return comparable to those of its respective bond index, the Advisor will monitor the Fund's portfolio and market changes. The calculation of a Fund's duration and average portfolio maturity will be based on certain estimates relating to the duration and maturity of the debt obligations held by the Fund. There can be no assurance that these estimates will be accurate. The value of a Fund's portfolio, as is generally the case with each bond index, can be expected to vary inversely from changes in prevailing interest rates.

Options Trading. As a non-principal investment strategy, the Funds may purchase put and call options for hedging purposes. A Fund will not buy an option when the aggregate premiums on outstanding options held by the Fund exceed 5% of its net assets. Such options may relate to particular debt obligations or to various indices and may or may not be listed on a national securities exchange and issued by the Options Clearing Corporation. This is a highly specialized activity that entails greater than ordinary investment risks, including the complete loss of the amount paid as premiums to the writer of the option. Regardless of how much the market price of the underlying debt obligation or index increases or decreases, the option buyer's risk is limited to the amount of the original investment for the purchase of the option.

However, options may be more volatile than the underlying debt obligations or indices, and therefore, on a percentage basis, an investment in options may be subject to greater fluctuation than an investment in the underlying debt obligations. In contrast to an option on a particular debt obligation, an option on an index provides the holder with the right to make or receive a cash settlement upon exercise of the option. The amount of this settlement will be equal to the difference between the closing price of the index at the time of exercise and the exercise price of the option expressed in dollars, times a specified multiple.

The Funds will engage in unlisted over-the-counter options only with broker-dealers deemed creditworthy by the Advisor. Closing transactions in certain options are usually effected directly with the same broker-dealer that effected the original option transaction. The Funds bear the risk that the broker-dealer will fail to meet its obligations. There is no assurance that a liquid secondary trading market exists for closing out an unlisted option position. Furthermore, unlisted options are not subject to the protections afforded purchasers of listed options by the Options Clearing Corporation, which performs the obligations of its members who fail to perform in connection with the purchase or sale of options.

A call option gives the purchaser of the option the right to buy, and a writer the obligation to sell, the underlying debt obligation or index at the stated exercise price at any time prior to the expiration of the option, regardless of the market price of the debt obligation. The premium paid to the writer is in consideration for undertaking the obligations under the option contract. A put option gives the purchaser the right to sell the underlying debt obligation or index at the stated exercise price at any time prior to the expiration date of the option, regardless of the market price of the debt obligation or index. Put and call options purchased by a Fund will be valued at the last sale price or, in the absence of such a price, at the mean between bid and asked prices.

Risks associated with transactions in options on debt obligations and indices include (i) an imperfect correlation between the change in market value of the debt obligations a Fund holds and the prices of options relating to the securities purchased or sold by the Fund; and (ii) the possible lack of a liquid secondary market for an option. A decision as to whether, when and how to use options involves the exercise of skill and judgment, and a transaction may be unsuccessful to some degree because of market behavior or unexpected events.

Futures Contracts and Related Options. As a non-principal investment strategy, a Fund may purchase or sell futures contracts, or options thereon, as a hedge against changes resulting from market conditions in the value of the debt obligations held by the Fund, or of debt obligations which the Fund intends to purchase to maintain liquidity, to have fuller exposure to price movements in the respective bond index or to reduce transaction costs. For example, a Fund may enter into transactions involving a bond or stock index futures contract, which is a bilateral agreement pursuant to which the parties agree to take or make delivery of an amount of cash equal to a specified dollar amount times the difference between the index value (which assigns relative values to the debt obligations included in the index) at the close of the last trading day of the contract and the price at which the futures contract is originally struck. No physical delivery of the underlying bonds or stocks in the index is made. A Fund may also purchase or sell interest rate futures contracts, or options thereon, which provide for the future delivery of specified fixed-income debt obligations.

A bond or stock index assigns relative values to the debt obligations included in the index and the index fluctuates with changes in the market values of the debt obligations included. Futures contracts are traded on organized exchanges regulated by the Commodity Futures Trading Commission (the "CFTC"). Transactions on such exchanges are cleared through a clearing corporation, which guarantees the performance of the parties to each contract.

The Funds may sell index futures contracts. The Funds may do so either to hedge the value of their portfolios as a whole, or to protect against declines, occurring prior to sales of debt obligations, in the value of the debt obligations to be sold. Conversely, the Funds may purchase index futures contracts. In a substantial majority of these transactions, the Funds will purchase such debt obligations upon termination of the long futures position, but a long futures position may be terminated without a corresponding purchase of debt obligations.

In addition, the Funds may utilize index futures contracts in anticipation of changes in the composition of their portfolio holdings. For example, in the event that a Fund expects to narrow the range of industry groups represented in its holdings, it may, prior to making purchases of the actual debt obligations, establish a long futures position based on a more restricted index, such as an index comprised of debt obligations of a particular industry group. The Fund may also sell futures contracts in connection with this strategy, in order to protect against the possibility that the value of the debt obligations to be sold as part of the restructuring of the portfolio will decline prior to the time of sale.

Positions in futures contracts may be closed out only on an exchange that provides a secondary market for such futures. However, there can be no assurance that a liquid secondary market will exist for any particular futures contract at any specific time. Thus, it may not be possible to close a futures position. In the event of adverse price movements, a Fund would continue to be required to make daily cash payments to maintain its required margin. In such situations, if a Fund has insufficient cash, it may have to sell portfolio holdings to meet daily margin requirements at a time when it may be disadvantageous to do so. In addition, a Fund may be required to make delivery of the instruments underlying futures contracts it holds. The inability to close options and futures positions also could have an adverse impact on a Fund's ability to effectively hedge.



Successful use of futures by the Funds is also subject to the Advisor's ability to correctly predict movements in the direction of the market. For example, if a Fund has hedged against the possibility of a decline in the market adversely affecting debt obligations held by it and debt obligations prices increase instead, the Fund will lose part or all of the benefit to the increased value of its debt obligations which it has hedged because the Fund will have approximately equal offsetting losses in its futures positions. In addition, in some situations, if a Fund has insufficient cash, it may have to sell debt obligations to meet daily variation margin requirements. Such sales of debt obligations may be, but will not necessarily be, at increased prices that reflect the rising market. A Fund may have to sell debt obligations at a time when it may be disadvantageous to do so.

Unlike when the Funds purchase or sell a debt obligation, no price is paid or received by the Funds upon the purchase or sale of a futures contract. Initially, in accordance with the terms of the exchange on which such futures contract is traded, a Fund may be required to deposit with the broker or in a segregated account with the Fund's custodian an amount of cash or cash equivalents, the value of which may vary but is generally equal to 10% or less of the value of the contract. This amount is known as initial margin. The initial margin is in the nature of a performance bond or good faith deposit on the contract which is returned to the Fund upon termination of the futures contract assuming all contractual obligations have been satisfied. Subsequent payments, called variation margin, to and from the broker, will be made on a daily basis as the price of the underlying debt obligation or index fluctuates making the long and short positions in the futures contract more or less valuable, a process known as marking to the market.

The risk of loss in trading futures contracts in some strategies can be substantial, due both to the low margin deposits required, and extremely high degree of leverage involved in futures pricing. As a result, a relatively small price movement in a futures contract may result in immediate and substantial loss (as well as gain) to the investor. For example, if at the time of purchase, 10% of the value of the futures contract is deposited as margin, a subsequent 10% decrease in the value of the futures contract would result in a total loss of the margin deposit, before any deduction for the transaction costs, if the account were then closed out. A 15% decrease would result in a loss equal to 150% of the original margin deposit, before any deduction for the transaction costs, if the contract were closed out. Thus, a purchase or sale of a futures contract may result in losses in excess of the amount invested in the contract.

Risks associated with the use of futures contracts and options on futures include (a) imperfect correlation between the change in market values of the debt obligations held by a Fund and the prices of related futures contracts and options on futures purchased or sold by the Fund; and (b) the possible lack of a liquid secondary market for futures contracts (or related options) and the resulting inability of the Fund to close open futures positions, which could have an adverse impact on the Fund's ability to hedge.

Most futures exchanges limit the amount of fluctuation permitted in futures contract prices during a single trading day. The daily limit establishes the maximum amount that the price of a futures contract may vary either up or down from the previous day's settlement price at the end of a trading session. Once the daily limit has been reached in a particular type of contract, no trades may be made on that day at a price beyond that limit. The daily limit governs only price movement during a particular trading day and therefore does not limit potential losses, because the limit may prevent the liquidation of unfavorable positions. Futures contract prices have occasionally moved to the daily limit for several consecutive trading days with little or no trading, thereby preventing prompt liquidation of futures positions and subjecting some futures traders to substantial losses.

Utilization of futures transactions by a Fund involves the risk of loss by the Fund of margin deposits in the event of bankruptcy of a broker with whom the Fund has an open position in a futures contract or related option. The trading of futures contracts is also subject to the risk of trading halts, suspensions, exchange or clearing house equipment failures, government intervention, insolvency of a brokerage firm or clearing

house or other disruptions of normal trading activity, which could at times make it difficult or impossible to liquidate existing positions or to recover excess variation margin payments.

The purchase or sale of an option also entails the risk that changes in the value of the underlying futures contract will not be fully reflected in the value of the option purchased. Depending on the pricing of the option compared to either the futures contract upon which it is based, or upon the price of the debt obligations being hedged, an option may or may not be less risky than ownership of the futures contract or such debt obligations. In general, the market prices of options can be expected to be more volatile than the market prices on the underlying futures contract. Compared to the purchase or sale of futures contracts, however, the purchase of call or put options on futures contracts may frequently involve less potential risk to a Fund because the maximum amount at risk is the premium paid for the options (plus transaction costs). The regulation of futures and options in the U.S. is a rapidly changing area of law and is subject to change by governmental or regulatory action.

In connection with a futures transaction, unless the transaction is covered in accordance with the Securities and Exchange Commission (the “SEC”) positions, a Fund will maintain a segregated account with its custodian or sub-custodian consisting of cash or liquid debt obligations equal to the entire amount at risk (less margin deposits) on a continuous basis. Each Fund’s commodities transactions must be made solely for bona fide hedging purposes as defined by the Commodities Futures Trading Commission. In addition, the Fund may invest in commodity interests for other than bona fide hedging purposes if it meets either the 5% trading de minimis test (the “5% Test”) or a test based on the net notional value of the Fund’s commodities transactions (the “Notional Test”). Under the 5% Test, the aggregate initial margin and premiums required to establish positions in commodity futures, commodity options or swaps may not exceed 5% of the Fund’s net asset value. Under the Notional Test, the aggregate net notional value of commodity futures, commodity options or swaps not used solely for bona fide hedging purposes may not exceed 100% of the Fund’s net asset value. The Company has filed a notice of eligibility for exclusion from the definition of the term “commodity pool operator” in accordance with Rule 4.5 under the Commodity Exchange Act (the “CEA”) and, therefore, is not subject to registration or regulation as a commodity pool operator under the CEA.

Each Fund intends to limit its transactions in futures contracts and related options so that it complies with the 5% test.

#### Cash or Similar Investments; Temporary Strategies

Under normal market conditions, each Fund may invest up to 20% of its net assets in cash or similar short-term, investment grade securities such as U.S. government securities, repurchase agreements, commercial paper or certificates of deposit. In limited circumstances, to retain the flexibility to respond promptly to changes in market, economic or political conditions or in the case of unusually large cash inflows or redemptions, the Advisor may invest up to 100% of the total assets of each of the Funds in cash or similar investments (such as U.S. government securities, repurchase agreements, commercial paper or certificates of deposit). When a Fund takes a temporary position, the Fund may not achieve its investment objective.

#### Cybersecurity Risk

With the increased use of technologies such as the Internet to conduct business, the Funds are susceptible to operational, information security and related risks. In general, cyber incidents can result from deliberate attacks or unintentional events. Cyber attacks include, but are not limited to, gaining unauthorized access to digital systems (e.g., through “hacking” or malicious software coding) for purposes of misappropriating assets or sensitive information, corrupting data, or causing operational disruption. Cyber attacks may also

be carried out in a manner that does not require gaining unauthorized access, such as causing denial-of-service attacks on websites (*i.e.*, efforts to make network services unavailable to intended users). Cyber incidents affecting the Funds or their service providers have the ability to cause disruptions and impact business operations, potentially resulting in financial losses, interference with a Fund's ability to calculate its net asset value ("NAV"), impediments to trading, the inability of fund shareholders to transact business, violations of applicable privacy and other laws, regulatory fines, penalties, reputational damage, reimbursement or other compensation costs, or additional compliance costs. Similar adverse consequences could result from cyber incidents affecting issuers of securities in which a Fund invests, counterparties with which a Fund engages in transactions, governmental and other regulatory authorities, exchange and other financial market operators, banks, brokers, dealers, insurance companies and other financial institutions (including financial intermediaries and service providers for fund shareholders) and other parties. In addition, substantial costs may be incurred in order to prevent any cyber incidents in the future. While the Funds' service providers have established business continuity plans in the event of, and risk management systems to prevent, such cyber incidents, there are inherent limitations in such plans and systems including the possibility that certain risks have not been identified. Furthermore, the Funds cannot control the cyber security plans and systems put in place by its service providers or any other third parties whose operations may affect the Funds or their shareholders. As a result, the Funds and their shareholders could be negatively impacted.

#### Other Investment Considerations – Principal Investment Strategies

The Funds' cash balances may be invested in short-term municipal notes and tax-exempt commercial paper or variable rate demand obligations, as well as municipal bonds with remaining maturities of thirteen months or less and securities issued by other investment companies which invest in high quality, short-term municipal debt obligations. The value of the Funds' portfolios can be expected to vary inversely to changes in prevailing interest rates.

From time to time, on a temporary defensive basis due to market conditions, the Funds may hold without any limitation uninvested cash reserves and invest without any limitations in high quality, short-term taxable money market obligations in such proportions as in the opinion of the Advisor, prevailing market or economic conditions warrant. Uninvested cash reserves will not earn income. Taxable obligations acquired by the Funds will not exceed under normal conditions 20% of the Funds' net assets at the time of purchase.

Municipal Obligations. Municipal obligations which may be acquired by the Funds include debt obligations issued by states, possessions and territories of the U.S., including political subdivisions (such as counties, cities, towns and school and other districts), agencies and authorities thereof. Municipal obligations are issued by such governmental entities to obtain funds for various public purposes, including the construction of a wide range of public facilities, the refunding of outstanding obligations, the payment of general operating expenses and the extension of loans to public institutions and facilities, not-for-profit organizations, businesses and developers. Types of municipal obligations in which the Funds may invest include, but are not limited to, the following:

*General Obligation Bonds.* General obligation bonds are supported by the issuer's full faith and credit and taxing authority. The issuer must levy and collect taxes sufficient to pay principal and interest on the bonds. However, in some cases the issuer's authority to levy additional taxes may be limited by its charter or state law.

*Revenue Bonds.* Revenue bonds are payable solely from specific income or revenues received by the issuer, often from its operation of a governmental enterprise or authority such as an electric or water utility, sewer system, parks, hospitals or other health authority, bus, train, subway, highway, airport or other

transportation system, or housing authority. Some revenue bonds may be issued for other public purposes, such as financing the development of an industrial park or commercial district or construction of a new stadium, parking structure or stadium. The revenues may consist of specific taxes, assessments, tolls, fees, or other types of municipal revenues. Although issued by municipal authorities, revenue bonds are generally not secured by the taxing power of the municipality but by the revenues of the authority derived from payments by users of the services or owners and operators of the facility financed with the proceeds of the bonds. Bonds or other obligations of housing financing authorities may have various forms of security, such as reserve funds, insured or subsidized mortgages and net revenues from projects, but they are not backed by a pledge of the issuer's credit. The credit quality of revenue bonds is usually related to the credit standing of the enterprise being financed but can, if applicable, be tied to the credit worthiness of an institution which provides a guarantee, letter of credit or other credit enhancement for the bond issue.

*Private Activity Bonds.* Private activity bonds are special revenue bonds used to finance private entities. For example, a municipality may issue bonds to finance a new factory to improve its local economy or to enable a college or university, not-for-profit organization or hospital to construct new or expanded facilities. The municipality would lend the proceeds to the company or other entity, and the company or other entity would agree to make loan payments sufficient to repay the bonds. The bonds would be payable solely from the borrower's loan payments, and not from any other revenues of the municipality. Therefore, any default on the loan normally would result in a default on the bonds. The interest on many types of private activity bonds is subject to the federal alternative minimum tax ("AMT"). The Funds may invest in bonds subject to the federal AMT. Each Fund is limited by its fundamental investment limitation in the amount it can invest in securities that may be subject to federal AMT (see "Investment Objectives and Limitations").

*Anticipation Notes.* Anticipation notes are securities issued in anticipation of the receipt of taxes, grants, bond proceeds, or other municipal revenues. These may be in the form of bond anticipation notes, tax anticipation notes, tax and revenue anticipation notes, and revenue anticipation notes. For example, many municipalities collect property taxes once a year. Such municipalities may issue tax anticipation notes to fund their operations prior to collecting these taxes. The issuers then repay the tax anticipation notes at the end of their fiscal year, either with collected taxes or proceeds from newly issued notes or bonds. Bond anticipation notes are notes that are intended to be refinanced through a subsequent offering of longer term bonds.

*Tax Increment Financing Bonds.* Tax increment financing bonds are payable from increases in taxes or other revenues attributable to higher valuations on the businesses benefitting from improvements made to a particular area or district financed by the bonds. For example, a municipality may issue these bonds to redevelop a commercial area. The tax increment financing bonds would be payable solely from any increase in sales taxes collected from merchants in the area or in property taxes collected from property owners. The bonds could default if merchants' sales or owners' property valuations, and related tax collections, failed to increase as anticipated.

Municipal obligations also include municipal commercial paper and other short-term notes, variable rate demand obligations, industrial revenue bonds, pre-refunded or advance refunding bonds, municipal lease obligations, construction loan notes insured by the Federal Housing Administration and financed by FNMA or GNMA, and participation, trust and partnership interests in any of the foregoing.

Opinions relating to the validity of municipal obligations and to the exemption of interest thereon from federal income tax are rendered by bond counsel to the respective issuers at the time of issuance. Neither the Funds nor the Advisor will review the proceedings relating to the issuance of municipal obligations or the basis for such opinions. There can be no assurance that the Internal Revenue Service ("IRS") will agree

with a bond counsel's opinion concluding that interest on a particular obligation is exempt from federal income tax.

Certain of the municipal obligations held by the Funds may be insured at the time of issuance as to the timely payment of principal and interest. The insurance policies will usually be obtained by the issuer of the municipal obligation at the time of its original issuance. In the event that the issuer defaults on interest or principal payment, the insurer will be notified and will be required to make payment to the bondholders. There is, however, no guarantee that the insurer will meet its obligations. In addition, such insurance will not protect against market fluctuations caused by changes in interest rates and other factors, including credit downgrades, supply and demand. Each Fund may, from time to time, invest more than 25% of its assets in municipal obligations covered by insurance policies.

The payment of principal and interest on most debt obligations purchased by the Funds will depend upon the ability of the issuers to meet their obligations. Municipal obligations may be adversely affected by political and economic conditions and developments (for example, legislation reducing state aid to local governments.) An issuer's obligations under its municipal obligations are also subject to the provisions of bankruptcy, insolvency, and other laws affecting the rights and remedies of creditors, such as the Federal Bankruptcy Code, and laws, if any, which may be enacted by federal or state legislatures extending the time for payment of principal or interest, or both, or imposing other constraints upon enforcement of such obligations or upon the ability of municipalities to levy taxes. The power or ability of an issuer to meet its obligations for the payment of interest on, and principal of, its municipal obligations may be materially adversely affected by litigation or other conditions.

Certain types of municipal obligations (private activity bonds) have been or are issued to obtain funds to provide privately operated housing facilities, pollution control facilities, convention or trade show facilities, mass transit, airport, port or parking facilities and certain local facilities for water supply, gas, electricity or sewage or solid waste disposal. Private activity bonds are also issued on behalf of privately held or publicly owned corporations in the financing of commercial or industrial facilities. State and local governments are authorized in most states to issue private activity bonds for such purposes in order to encourage corporations to locate within their communities. The principal and interest on these obligations may be payable from the general revenues of the users of such facilities.

Municipal obligations purchased by the Funds may be backed by letters of credit issued by foreign and domestic banks and other financial institutions. Such letters of credit are not necessarily subject to federal deposit insurance and adverse developments in the banking industry could have a negative effect on the credit quality of the Funds' portfolio debt obligations and its ability to maintain a stable net asset value and share price. Letters of credit issued by foreign banks, like other obligations of foreign banks, may involve certain risks in addition to those of domestic obligations.

The Funds may purchase put options on municipal obligations. A put gives the Funds the right to sell a municipal obligation at a specified price at any time before a specified date. A put will be sold, transferred or assigned only with the related municipal obligation. The Funds will acquire puts only to enhance liquidity, shorten the maturity of the related municipal debt obligation or permit the Funds to invest its assets at more favorable rates. The aggregate price of a debt obligation subject to a put may be higher than the price which otherwise would be paid for the debt obligation without such an option, thereby increasing the debt obligation's cost and reducing its yield.

From time to time, proposals have been introduced before Congress for the purpose of restricting or eliminating the federal income tax exemption for interest on municipal obligations. For example, under the Internal Revenue Code of 1986, as amended (the "Code"), interest on certain private activity bonds must be included in an investor's alternative minimum taxable income, and corporate investors must include all

tax-exempt interest in their calculations of federal alternative minimum taxable income. The Company cannot, of course, predict what legislation, if any, may be proposed in the future as regards the income tax status of interest on municipal obligations, or which proposals, if any, might be enacted. Such proposals, while pending or if enacted, might materially and adversely affect the availability of municipal obligations for investment by the Funds and the liquidity and value of its portfolio. In such an event, the Company would reevaluate the Funds' investment objective and policies and consider possible changes in its structure or possible dissolution.

Municipal Lease Obligations. As stated in the Prospectus, the Funds may acquire municipal lease obligations that are issued by a state or local government authority to acquire land and a wide variety of equipment and facilities. These obligations typically are not fully backed by the municipality's credit, and their interest may become taxable if the lease is assigned. If the funds are not appropriated for the following year's lease payments, the lease may terminate, with the possibility of default on the lease obligation and significant loss to the Funds. Certificates of participation in municipal lease obligations or installment sale contracts entitle the holder to a proportionate interest in the lease-purchase payments made. The Advisor determines and monitors the liquidity of municipal lease obligations (including certificates of participation) under guidelines approved by the Board requiring the Advisor to evaluate the credit quality of such obligations and report on the nature of and the Funds' trading experience in the municipal lease market. Under the guidelines, municipal lease obligations that are not readily marketable and transferable are treated as illiquid. In making a determination that a municipal lease obligation is liquid, the Advisor may consider, among other things (i) whether the lease can be canceled; (ii) the likelihood that the assets represented by the lease can be sold; (iii) the strength of the lessee's general credit; (iv) the likelihood that the municipality will discontinue appropriating funds for the leased property because the property is no longer deemed essential to the operations of the municipality; and (v) availability of legal recourse in the event of failure to appropriate.

Stand-By Commitments. The Funds may acquire "stand-by commitments" with respect to municipal obligations held in its portfolio. Under a "stand-by commitment" a dealer agrees to buy from the Funds, at the Funds' option, specified municipal obligations at a specified price. A "stand-by commitment" acquired by the Funds may also be referred to in this SAI as a "put" option.

The amount payable to a Fund upon its exercise of a "stand-by commitment" is normally (i) the Fund's acquisition cost of the municipal obligations (excluding any accrued interest which the Fund paid on their acquisition), less any amortized market premium or plus any amortized market or original issue discount during the period the Fund owned the debt obligations; plus (ii) all interest accrued on the debt obligations since the last interest payment date during that period. A stand-by commitment may be sold, transferred or assigned by the Fund only with the instrument involved.

The Funds expect that "stand-by commitments" will generally be available without the payment of any direct or indirect consideration. However, if necessary or advisable, the Funds may pay for a "stand-by commitment" either separately in cash or by paying a higher price for the portfolio debt obligations which are acquired subject to the commitment (thus reducing the yield to maturity otherwise available for the same debt obligations). The total amount paid in either manner for outstanding "stand-by commitments" held by a Fund will not exceed 1/2 of 1% of the value of its total assets calculated immediately after each "stand-by commitment" is acquired.

The Funds intend to enter into "stand-by commitments" only with dealers, banks and broker-dealers which, in the Advisor's opinion, present minimal credit risks. The Funds' reliance upon the credit of these dealers, banks and broker-dealers is secured by the value of the underlying municipal obligations that are subject to a commitment.

The Funds would acquire “stand-by commitments” solely to facilitate portfolio liquidity and do not intend to exercise their rights thereunder for trading purposes. The acquisition of a “stand-by commitment” would not affect the valuation or assumed maturity of the underlying municipal debt obligations, which would continue to be valued in accordance with the ordinary method of valuation employed by the Funds. “Stand-by commitments” which would be acquired by the Funds would be valued at zero in determining net asset value. Where the Funds paid any consideration directly or indirectly for a “stand-by commitment” its cost would be reflected as unrealized depreciation for the period during which the commitment was held by the Funds.

Variable and Floating Rate Instruments. Municipal obligations purchased by the Funds may include variable and floating rate instruments issued by industrial development authorities and other governmental entities. With respect to the variable and floating rate instruments that may be acquired by the Funds, the Advisor will consider the earning power, cash flows and other liquidity ratios of the issuers and guarantors of such instruments and, if the instrument is subject to a demand feature, will monitor their financial status to meet payment on demand. In determining average weighted portfolio maturity, an instrument will usually be deemed to have a maturity equal to the longer of the period remaining to the next interest rate adjustment or the time the Funds can recover payment of principal as specified in the instrument. Variable U.S. government obligations held by the Funds, however, will be deemed to have maturities equal to the period remaining until the next interest rate adjustment.

When-Issued Purchases, Delayed Delivery and Forward Commitments. As a principal investment strategy, the Funds may purchase or sell particular debt obligations with payment and delivery taking place at a later date. The price or yield obtained in a transaction may be less favorable than the price or yield available in the market when the debt obligations delivery takes place. When a Fund agrees to purchase debt obligations on a when-issued or delayed delivery basis or enter into a forward commitment to purchase debt obligations, it will set aside cash or liquid securities equal to the amount of the commitment. Normally, the Fund will segregate on its records portfolio debt obligations to satisfy a purchase commitment, and in such a case a Fund may be required subsequently to segregate on the Fund’s records additional assets in order to ensure that the segregated value remains equal to the amount of the Fund’s commitments. It may be expected that the market value of a Fund’s net assets will fluctuate to a greater degree when portfolio debt obligations are segregated on the Fund’s records to cover such purchase commitments than when cash is set aside. In the case of a forward commitment to sell portfolio debt obligations, a Fund will segregate on its records the portfolio debt obligations while the commitment is outstanding. When-issued and forward commitment transactions involve the risk that the price or yield obtained in a transaction (and therefore the value of a debt obligation) may be less favorable than the price or yield (and therefore the value of a debt obligation) available in the market when the debt obligations delivery takes place.

The Funds will make commitments to purchase debt obligations on a when-issued basis or to purchase or sell debt obligations on a forward commitment basis only with the intention of completing the transaction and actually purchasing or selling the debt obligations. If deemed advisable as a matter of investment strategy, however, a Fund may dispose of or renegotiate a commitment after it is entered into, and may sell debt obligations it has committed to purchase before those debt obligations are delivered to the Fund on the settlement date. In these cases, a Fund may realize capital gains or losses.

When the Funds engage in when-issued, delayed delivery and forward commitment transactions, the Funds rely on the other party to consummate the trade. Failure of such party to do so may result in a Fund incurring a loss or missing an opportunity to obtain a price considered to be advantageous.

The market value of the debt obligations underlying a when-issued purchase or a forward commitment to purchase debt obligations, and any subsequent fluctuations in their market value, are taken into account

when determining the net asset value of a Fund starting on the day the Fund agrees to purchase the debt obligations. A Fund does not earn interest on the debt obligations the Fund has committed to purchase until they are paid for and delivered on the settlement date. When a Fund makes a forward commitment to sell debt obligations it owns, the proceeds to be received upon settlement are included in the Fund's assets. Fluctuations in the market value of the underlying debt obligations are not reflected in a Fund's net asset value as long as the commitment remains in effect.

Non-Investment Grade Debt Obligations (High Yield Bonds). Each Fund may invest up to 10% of its net assets at the time of purchase in non-investment grade debt obligations. While generally offering higher yields than investment grade debt with similar maturities, non-investment grade debt obligations involve greater risks, including the possibility of default or bankruptcy. They are regarded as predominantly speculative with respect to the issuer's capacity to pay interest and repay principal. The special risk considerations in connection with investments in these debt obligations are discussed below.

*Effect of Interest Rates and Economic Changes.* All interest-bearing debt obligations typically experience appreciation when interest rates decline and depreciation when interest rates rise. The market values of non-investment grade debt obligations tend to reflect individual corporate developments to a greater extent than do higher-rated debt obligations, which react primarily to fluctuations in the general level of interest rates. Non-investment grade debt obligations also tend to be more sensitive to economic conditions than are higher-rated obligations. As a result, they generally involve more credit risks than debt obligations in the higher-rated categories. During an economic downturn or a sustained period of rising interest rates, highly leveraged issuers of non-investment grade debt obligations may experience financial stress and may not have sufficient revenues to meet their payment obligations. The risk of loss due to default by an issuer of these debt obligations is significantly greater than issuers of higher-rated debt obligations because such debt obligations are generally unsecured and are often subordinated to other creditors. Further, if the issuer of a non-investment grade debt obligation defaulted, the Funds might incur additional expenses to seek recovery. Periods of economic uncertainty and changes would also generally result in increased volatility in the market prices of these debt obligations and thus in each Fund's net asset value.

*Payment Expectations.* Non-investment grade debt obligations typically contain redemption, call or prepayment provisions which permit the issuer of such obligations containing such provisions to redeem the obligations at its discretion. During periods of falling interest rates, issuers of these obligations are likely to redeem or prepay the obligations and refinance them with debt obligations with a lower interest rate. To the extent an issuer is able to refinance the obligations, or otherwise redeem them, the Funds may have to replace the debt obligations with a lower yielding debt obligation, which could result in a lower return for the Funds.

*Credit Ratings.* Credit ratings issued by credit-rating agencies evaluate the safety of principal and interest payments of rated debt obligations. They do not, however, evaluate the market value risk of non-investment grade debt obligations and, therefore, may not fully reflect the true risks of an investment. In addition, credit rating agencies may or may not make timely changes in a rating to reflect changes in the economy or in the condition of the issuer that affect the market value of the debt obligation. Consequently, credit ratings are used only as a preliminary indicator of investment quality. Investments in non-investment grade debt obligations will be more dependent on the Advisor's credit analysis than would be the case with investments in investment grade debt obligations. The Advisor employs its own credit research and analysis, which includes a study of existing debt, capital structure, ability to service debt and to pay dividends, the issuer's sensitivity to economic conditions, its operating history and the current trend of earnings. The Advisor continually monitors the Funds' investments and carefully evaluates whether to dispose of or to retain non-investment grade debt obligations whose credit ratings or credit quality may have changed.



*Liquidity and Valuation.* The Funds may have difficulty disposing of certain non-investment grade debt obligations because there may be a thin trading market for such debt obligations. Because not all dealers maintain markets in all non-investment grade debt obligations there is no established retail secondary market for many of these debt obligations. The Funds anticipate that such debt obligations could be sold only to a limited number of dealers or institutional investors. To the extent a secondary trading market does exist, it is generally not as liquid as the secondary market for higher-rated debt obligations. The lack of a liquid secondary market may have an adverse impact on the market price of the debt obligation. The lack of a liquid secondary market for certain debt obligations may also make it more difficult for the Funds to obtain accurate market quotations for purposes of valuing the Funds. Market quotations are generally available on many non-investment grade debt obligations issues only from a limited number of dealers and may not necessarily represent firm bids of such dealers or prices for actual sales. During periods of thin trading, the spread between bid and asked prices is likely to increase significantly. In addition, adverse publicity and investor perceptions, whether or not based on fundamental analysis, may decrease the values and liquidity of non-investment grade debt obligations, especially in a thinly traded market.

### Portfolio Turnover

The portfolio turnover rate for a Fund is calculated by dividing the lesser of amounts of purchases or sales of portfolio debt obligations for the reporting period by the monthly average value of the portfolio debt obligations owned during the reporting period. The calculation excludes all debt obligations, including options, whose maturities or expiration dates at the time of acquisition are one year or less. Portfolio turnover may vary greatly from year to year as well as within a particular year, and may be affected by cash requirements for redemption of shares and by requirements which enable the Funds to receive favorable tax treatment. Portfolio turnover will not be a limiting factor in making portfolio decisions, and the Funds may engage in short-term trading to achieve their respective investment objectives.

Each Fund may sell a portfolio investment soon after its acquisition if the Advisor believes that such a disposition is consistent with attaining the investment objective of a Fund. Portfolio investments may be sold for a variety of reasons, such as a more favorable investment opportunity or other circumstances bearing on the desirability of continuing to hold such investments. A high rate of portfolio turnover (over 100%) may involve correspondingly greater transaction costs, which must be borne directly by a Fund and ultimately by its shareholders. High portfolio turnover may result in the realization of substantial net capital gains. To the extent net short-term capital gains are realized, distributions attributable to such gains will be taxed at ordinary income rates (for non-corporate shareholders, currently as high as 39.6%) for federal income tax purposes.

## **INVESTMENT OBJECTIVES AND LIMITATIONS**

### Investment Objectives

The investment objective of a Fund cannot be changed without shareholder approval, which requires the approval of a “majority of the Fund’s outstanding voting securities,” as defined below.

### Fundamental Investment Limitations

The Funds are subject to the fundamental investment limitations enumerated in this subsection, which may be changed only by a vote of the holders of a majority of the Fund’s outstanding voting securities. A “majority of the outstanding voting securities” of a Fund means the lesser of (1) 67% of the shares of common stock of the Fund represented at a meeting at which the holders of more than 50% of the outstanding shares of the Fund are present in person or by proxy; or (2) more than 50% of the outstanding shares of the Fund.

Each Fund:

1. May not, with respect to 75% of its total assets, purchase the securities of any one issuer (except securities issued or guaranteed by the U.S. government, or its agencies or instrumentalities) if, as a result, (i) more than 5% of the Fund's total assets would be invested in the securities of that issuer; or (ii) the Fund would hold more than 10% of the outstanding voting securities of that issuer.
2. May (i) borrow from banks for temporary or emergency purposes (but not for leveraging or the purchase of investments); and (ii) make other investments or engage in other transactions permissible under the 1940 Act, which may involve a borrowing, including borrowing through reverse repurchase agreements, provided that the combination of (i) and (ii) shall not exceed  $33\frac{1}{3}$  of the value of the Fund's total assets (including the amount borrowed), less the Fund's liabilities (other than borrowings). If the amount borrowed at any time exceeds  $33\frac{1}{3}$  of the Fund's total assets, the Fund will, within three days thereafter (not including Sundays, holidays and any longer permissible period), reduce the amount of the borrowings such that the borrowings do not exceed  $33\frac{1}{3}$  of the Fund's total assets. The Fund may also borrow money from other persons to the extent permitted by applicable laws.
3. May not issue senior securities, except as permitted under the 1940 Act.
4. May not act as an underwriter of another issuer's securities, except to the extent that the Fund may be deemed to be an underwriter within the meaning of the 1933 Act, in connection with the purchase and sale of portfolio securities.
5. May not purchase or sell physical commodities unless acquired as a result of ownership of other securities or other instruments (but this shall not prevent the Fund from purchasing or selling options, futures contracts or other derivative instruments, or from investing in securities or other instruments backed by physical commodities).
6. May not make loans if, as a result, more than  $33\frac{1}{3}$  of the Fund's total assets would be lent to other persons, except through (i) purchases of debt securities or other debt instruments; or (ii) engaging in repurchase agreements.
7. May not purchase the securities of any issuer if, as a result, 25% or more of the Fund's total assets would be invested in the securities of issuers, the principal business activities of which are in the same industry; provided, however, that there is no limitation with respect to instruments issued or guaranteed by the United States, any state, territory or possession of the United States, the District of Columbia or any of their authorities, agencies, instrumentalities or political subdivisions and repurchase agreements secured by such instruments.
8. May not purchase or sell real estate, unless acquired as a result of ownership of securities or other instruments (but this shall not prohibit the Fund from purchasing or selling securities or other instruments backed by real estate or of issuers engaged in real estate activities).
9. May not invest less than 80% of its net assets in securities the interest on which is exempt from federal income tax, except during defensive periods or during unusual market conditions. For purposes of this fundamental policy, municipal obligations that are subject to federal alternative minimum tax are considered taxable.

With respect to Fundamental Investment Limitation No. 2, "any longer permissible period" means any longer period authorized by the SEC in accordance with Section 18(f)(1) of the 1940 Act and "applicable laws" means the 1940 Act, any rule, regulation or exemptive order thereunder or SEC staff interpretation

thereof. Under SEC staff interpretations, reverse repurchase agreements, firm commitment agreements and standby commitment agreements will not constitute impermissible borrowings under the 1940 Act if the Funds segregate assets or otherwise covers their obligations to limit the Funds' risk of loss. The Funds do not currently intend to invest in such investments.

Under the 1940 Act, in addition to borrowing from banks, the Funds may borrow from other persons an additional amount not exceeding 5% of its total assets for temporary purposes. The Funds do not intend to borrow from parties other than banks.

With respect to Fundamental Investment Limitation No. 3, the 1940 Act permits the Funds to enter into options, futures contracts, forward contracts, repurchase agreements and reverse repurchase agreements provided that these types of transactions are covered in accordance with SEC positions. Under SEC staff interpretations of the 1940 Act, such derivative transactions will not be deemed "senior securities" if the Funds segregate assets or otherwise covers its obligations to limit the Funds' risk of loss, such as through offsetting positions.

With respect to Fundamental Investment Limitation No. 7, the Advisor determines industry classifications for the Funds in accordance with the Global Industry Classification Standards, an industry classification system developed by Standard & Poor's Corporation in collaboration with Morgan Stanley Capital International, or other classification sources maintained and developed by third parties. In the absence of such classification, or if the Advisor determines in good faith based on its own analysis that the economic characteristics affecting a particular issuer make it more appropriate to be considered engaged in a different industry, the Advisor may classify an issuer accordingly. Thus, the composition of an industry may change from time to time. Each Fund may be concentrated in a sector but will not be concentrated in any industry. There is no limitation with respect to instruments issued or guaranteed by the United States, any state, territory or possession of the United States, the District of Columbia or any of their authorities, agencies, instrumentalities or political subdivisions even though the proceeds from the sale of those instruments by such governmental authorities may be used to fund projects in particular industries.

With respect to Fundamental Investment Limitation No. 8, real estate shall include real estate mortgages.

Unless noted otherwise, if a percentage restriction is adhered to at the time of investment, a later increase or decrease in percentage resulting from a change in a Fund's assets (*i.e.*, due to cash inflows or redemptions) or in market value of the investment or the Fund's assets will not constitute a violation of that restriction. This does not, however, apply to the borrowing policy set forth above.

#### Non-Fundamental Investment Limitations

The following are the Funds' non-fundamental operating policies, which may be changed by the Board without shareholder approval.

Each Fund may not:

1. Sell securities short, unless the Fund owns or has the right to obtain securities equivalent in kind and amount to the securities sold short, or unless it covers such short sale as required by the current rules and positions of the SEC or its staff, and provided that transactions in options, futures contracts, options on futures contracts, or other derivative instruments are not deemed to constitute selling securities short.
2. Purchase securities on margin, except that the Fund may obtain such short-term credits as are necessary for the clearance of transactions; and provided that margin deposits in connection with futures

contracts, options on futures contracts, or other derivative instruments shall not constitute purchasing securities on margin.

3. Purchase securities of other investment companies except in compliance with the 1940 Act and applicable state law.
4. Make any loans, other than loans of portfolio securities, except through (i) purchases of debt securities or other debt instruments, or (ii) repurchase agreements.
5. Borrow money except from banks or through reverse repurchase agreements or mortgage dollar rolls.

Each Fund's non-fundamental investment policies listed above may be changed with the approval of the Board. Unless noted otherwise, if a percentage restriction is adhered to at the time of investment, a later increase or decrease in percentage resulting from a change in a Fund's assets (*i.e.*, due to cash inflows or redemptions) or in market value of the investment or a Fund's assets will not constitute a violation of that restriction. This does not, however, apply to the borrowing policy set forth above.

For purposes of each Fund's policy to invest a minimum percentage of its assets in investments suggested by the Fund's name, "assets" is defined as net assets plus borrowings for investment purposes.

### **NET ASSET VALUE**

Shares of the Funds are sold on a continual basis at the net asset value ("NAV") next computed following receipt of an order in proper form by a dealer, the Funds' distributor, Robert W. Baird & Co. Incorporated (the "Distributor"), or U.S. Bancorp Fund Services, LLC (the "Transfer Agent"). Shares of the Funds may be purchased or redeemed only on days the New York Stock Exchange ("NYSE") is open.

The NAV per share for each class of shares of a Fund is determined as of the close of regular trading on the NYSE (currently, 3:00 p.m., Central time), Monday through Friday, except on days the NYSE is not open. The NYSE is closed on the following holidays: New Year's Day, Martin Luther King, Jr. Day, Presidents' Day, Good Friday, Memorial Day, Independence Day, Labor Day, Thanksgiving Day, and Christmas Day. The NAV per share of a Fund is calculated separately for the Investor Class shares and Institutional Class shares by adding the value of all portfolio securities and other assets per class (including interest or dividends accrued, but not yet collected), subtracting the liabilities, and dividing the result by the number of outstanding shares of that class. The result, rounded to the nearest cent, is the NAV per share.

When determining NAV, expenses are accrued and applied daily. Debt obligations are generally valued using prices provided by an independent pricing service, which uses valuation methods such as matrix pricing and other analytical pricing models, market transactions and dealer quotations. Debt obligations purchased with a remaining maturity of 60 days or less are valued as described above, unless an evaluated price is not available, in which case such security is valued at acquisition cost, plus or minus any amortized discount or premium, or, if the Advisor does not believe amortized cost is reflective of the value of the security, the security is priced at fair value as described below. Investments in mutual funds are valued at their stated NAV. Common stocks and other equity-type securities are valued at the last sales price on the national securities exchange (other than NASDAQ) on which such securities are primarily traded, and with respect to equity securities traded on NASDAQ, such securities are valued using the NASDAQ Official Closing Price. However, securities traded on a national securities exchange (including NASDAQ) for which there were no transactions on a given day, and securities not listed on a national securities exchange (including NASDAQ), are valued at the average of the most recent bid and asked prices. Any securities or other assets for which market quotations are not readily available or are not priced by an independent

pricing service are valued at fair value as determined in good faith by the Advisor in accordance with procedures approved by the Board. In accordance with such procedures, when the primary pricing service does not provide a fully-evaluated price for a particular security, or has discontinued pricing a security, the Advisor may obtain prices from an alternative independent pricing service. If a secondary pricing service does not provide a price for the security, the security may be valued using a price provided by a dealer who was the underwriter for the issuance of the security or who makes a market in that security or similar securities. If prices from an alternative independent pricing service or dealer quotes are unavailable or deemed to be unreliable, fair value will be determined by a valuation committee of the Advisor. In certain limited circumstances, such as when a new issue security is not priced by a pricing service or a dealer, the security may be temporarily valued by the Advisor using a methodology approved by the Board. In determining fair value, the valuation committee applies valuation methods approved by the Board and takes into account all relevant factors and available information. Fair value pricing involves subjective judgments and there is no single standard for determining a debt obligation's fair value. As a result, different mutual funds could reasonably arrive at a different fair value for the same debt obligation. It is possible that the fair value determined for a debt obligation is materially different from the value that could be realized upon the sale of that debt obligation or from the values that other mutual funds may determine.

The unprecedented financial market volatility and lack of liquidity in certain sectors of the bond markets experienced since 2008 may cause the prices of some of the debt obligations held by the Funds to fluctuate significantly from day to day and from period to period. Most of the debt obligations held by the Funds are priced using evaluated prices provided by independent pricing services. Evaluated prices for debt obligations are based on various market inputs such as benchmark yields, reported trades, broker-dealer quotes, issuer spreads, two-sided markets, comparable debt obligations, bids, offers and reference data, as well as market indicators, and material issuer, industry and economic events. For mortgage- and asset-backed debt obligations, the pricing service also reviews collateral performance data. The pricing of certain fixed income securities, particularly under volatile market conditions, is subject to the evaluation inputs used by the respective pricing services and the price evaluator's judgment. As a result, prices provided by the Funds' pricing services may vary significantly on any given day from prices obtained from other sources and from prices that may be obtained from an actual sale of debt obligations.

The calculation of the NAV of a Fund may not take place contemporaneously with the determination of the prices of portfolio debt obligations used in such calculation. Events affecting the values of portfolio debt obligations that occur between the time their prices are determined and the close of the NYSE (normally, 3:00 p.m. Central time), and at other times, may not be reflected in the calculation of NAV of the Funds.

### **ADDITIONAL PURCHASE AND REDEMPTION INFORMATION**

Fees for Certain Shareholder Services. Broker-dealers and other financial intermediaries may be paid by the Advisor or the Distributor for advertising, distribution, administrative, sub-transfer agency or other shareholder services. These payments may be in addition to any amounts paid by the Funds under the distribution and shareholder servicing plan adopted by the Board (see "Distribution Plan," below). Depending on the terms of the particular account, broker-dealers and other financial intermediaries also may charge their customers fees for automatic investment, redemption and other services provided. Such fees may include, for example, account maintenance fees, compensating balance requirements or fees based upon account transactions, assets or income. The intermediaries are responsible for providing information concerning these services and any charges to any customer who must authorize the purchase of Fund shares prior to such purchase.

Suspension of Redemption Right. Under the 1940 Act, the Funds may suspend the right of redemption or postpone the date of payment for shares during any period when (a) trading on the NYSE is restricted by applicable rules and regulations of the SEC; (b) the NYSE is closed for other than customary weekend and

holiday closings; (c) the SEC has by order permitted such suspension; or (d) an emergency exists as determined by the SEC. The Funds may also suspend or postpone the recording of the transfer of their shares upon the occurrence of any of the foregoing conditions.

Redemption in Kind. The Company has filed an election pursuant to Rule 18f-1 under the 1940 Act which provides that, with respect to redemptions which the Company has the right to satisfy in assets other than cash, each Fund is obligated to redeem shares solely in cash up to \$250,000 or 1% of the NAV of the class of shares of the Fund being redeemed, whichever is less, for any one shareholder within a 90-day period. Any redemption beyond this amount may be made in assets other than cash. If so requested by a redeeming shareholder and subject to the Fund's approval, redemptions in-kind may be made entirely in debt obligations. For federal income tax purposes, redemptions in kind are taxed in the same manner as redemptions made in cash.

Involuntary Redemptions. In addition to the situations described in the Funds' Prospectus under "General Transaction Policies," a Fund may redeem shares involuntarily when appropriate under the 1940 Act, such as to reimburse the Fund for any loss sustained by reason of the failure of a shareholder to make full payment for shares purchased by the shareholder or to collect any charge relating to a transaction effected for the benefit of a shareholder which is applicable to Fund shares as provided in the Funds' Prospectus.

Exchange Privilege. By use of the exchange privilege, shareholders authorize the Transfer Agent to act on exchange instructions received in writing or by telephone from any person representing himself to be the shareholder, or, in some cases, the shareholder's registered representative or account representative of record, and believed by the Transfer Agent to be genuine. The Transfer Agent's records of such instructions are binding. The exchange privilege may be modified or terminated at any time upon notice to shareholders.

Shares in the Baird Fund from which the shareholder is withdrawing an investment will be redeemed at the NAV per share next determined on the date of receipt and such redemption will result in a taxable capital gain or loss for federal income tax purposes unless the shares are held by a tax-exempt investor or are held in a tax-deferred arrangement such as a 401(k) plan or IRA. Shares of the new Fund into which the shareholder is investing will be purchased at the NAV per share next determined after acceptance of the request by the Fund's Transfer Agent in accordance with the policies for accepting investments. Exchanges of shares will be available only in states where they may legally be made.

Automatic Investment Plan. The Funds offer an Automatic Investment Plan whereby a shareholder may automatically make purchases of shares of a Fund on a regular, monthly basis (\$100 minimum per transaction). Under the Automatic Investment Plan, a shareholder's designated bank or other financial institution debits a preauthorized amount from the shareholder's account each month and applies the amount to the purchase of Fund shares. The Automatic Investment Plan must be implemented with a financial institution that is a member of the Automated Clearing House. No service fee is currently charged by a Fund for participation in the Automatic Investment Plan.

The Automatic Investment Plan permits an investor to use "Dollar Cost Averaging" in making investments. Instead of trying to time market performance, a fixed dollar amount is invested in Fund shares at predetermined intervals. This may help investors reduce their average cost per share because the agreed upon fixed investment amount allows more Fund shares to be purchased during periods of lower Fund share prices and fewer Fund shares to be purchased during periods of higher Fund share prices. In order to be effective, Dollar Cost Averaging should usually be followed on a sustained, consistent basis. Investors should be aware, however, that Fund shares bought using Dollar Cost Averaging are purchased without regard to their price on the day of investment or to market trends. Dollar Cost Averaging does not assure a profit and does not protect against losses in a declining market. In addition, while investors may find

Dollar Cost Averaging to be beneficial, it will not prevent a loss if an investor ultimately redeems his Fund shares at a price that is lower than their purchase price.

Systematic Withdrawal Plan. The Funds offer shareholders a Systematic Withdrawal Plan, which allows a shareholder who owns shares of a Fund worth at least \$5,000 at current NAV at the time the shareholder initiates the Systematic Withdrawal Plan to designate that a fixed sum (\$50 minimum per transaction) be distributed to the shareholder or as otherwise directed at regular intervals.

In-Kind Payments. Payment for shares of a Fund may, in the discretion of the Fund, be made in the form of debt obligations that are permissible investments for the Fund as described in its Prospectus. For further information about this form of payment, contact the Funds (toll-free) at 1-866-44BAIRD. In connection with an in-kind debt obligations payment, a Fund will require, among other things, that the debt obligations be valued on the day of purchase in accordance with the pricing methods used by the Fund; that the Fund receives satisfactory assurances that it will have good and marketable title to the debt obligations received by it; that the debt obligations be in proper form for transfer to the Fund; that adequate information be provided to the Fund concerning certain tax matters relating to the debt obligations; and that the amount of the purchase be at least \$1,000,000. You may realize a taxable gain or loss on the contributed debt obligations at the time of the in-kind debt obligations payment.

Individual Retirement Accounts. The Company has a plan (the “Traditional IRA”) available for use by individuals with earned income who wish to use shares of a Fund as a funding medium for individual retirement saving. However, except for rollover contributions, an individual who has attained, or will attain, age 70 ½ before the end of the taxable year may only contribute to a Traditional IRA for his or her non-working spouse under age 70 ½.

The Company also has available a Roth Individual Retirement Account (the “Roth IRA”) for retirement saving for use by individuals with earned income. For 2015, a single individual with adjusted gross income of up to \$131,000 may contribute to a Roth IRA (for married couples filing jointly, the adjusted gross income limit is \$193,000), and contributions may be made even after the Roth IRA owner has attained age 70 ½, as long as the account owner has earned income.

The Company permits certain employers (including self-employed individuals) to make contributions to employees’ Traditional IRAs if the employer establishes a Simplified Employee Pension (“SEP”) plan.

Savings Incentive Match Plan for Employees of Small Employers (Investor Class Only). The Company also has available a simplified tax-favored retirement plan for employees of small employers (a “SIMPLE IRA Plan”). If an employer establishes a SIMPLE IRA Plan, contributions under the SIMPLE IRA Plan are made to eligible employees’ SIMPLE Individual Retirement Accounts (“SIMPLE IRAs”). Each eligible employee may choose to defer a percentage of his or her pre-tax compensation to the employee’s SIMPLE IRA. The employer must generally make an annual matching contribution to the SIMPLE IRA of each eligible employee equal to the employee’s salary reduction contributions, up to a limit of 3% of the employee’s compensation. Alternatively, the employer may make an annual non-discretionary contribution to the SIMPLE IRA of each eligible employee equal to 2% of each employee’s compensation.

In the SIMPLE IRA Plan and in Traditional and Roth IRAs, distributions of net investment income and net capital gains will be automatically reinvested.

The foregoing brief descriptions are not complete or definitive explanations of the SIMPLE IRA Plan, the Traditional IRA, or the Roth IRA available for investment in the Funds. Any person who wishes to establish a retirement plan account may do so by contacting the Funds (toll-free) at 1-866-44BAIRD. The complete plan documents and applications will be provided to existing or prospective shareholders upon

request, without obligation. The Company recommends that investors consult their attorneys or tax advisors to determine if the retirement programs described herein are appropriate for their needs.

### **DESCRIPTION OF SHARES**

The Company’s Articles of Incorporation authorize the Board to issue an indefinite number of shares of common stock, \$.01 par value per share, which is classified into a total of eleven series (two of which are listed below) (each, a “series” or “Fund”). Each series is divided into two classes designated as Investor Class shares and Institutional Class shares (each, a “Class”) and consists of the number of shares set forth next to its Fund name in the table below:

Class of Common Stock	Fund in which Stock Represents Interest	Number of Authorized Shares in Each Series
Investor Class Institutional Class	Short-Term Municipal Bond Fund	Indefinite Indefinite
Investor Class Institutional Class	Core Intermediate Municipal Bond Fund	Indefinite Indefinite

The remaining series of common stock representing interests in nine other investment portfolios are described in a separate SAI. The Board may classify or reclassify any particular class of shares into one or more additional series or classes. Each share of common stock of each class is entitled to one vote, and each share is entitled to participate equally in distributions of net investment income and net capital gains by the respective class of shares and in the residual assets of the respective class in the event of liquidation. However, each class of shares bears its own expenses, and the Investor Class has exclusive voting rights on matters pertaining to the distribution and shareholder servicing plan (see “Distribution Plan,” below).

### **ADDITIONAL INFORMATION CONCERNING TAXES**

Each Fund intends to qualify as a regulated investment company under Subchapter M of the Code, and to distribute its income to shareholders each year so that the Fund itself generally will be relieved of federal income and excise taxes. However, if a Fund were to fail to qualify as a regulated investment company and was unable to obtain relief from such failure: (1) the Fund would be taxed at regular corporate rates without any deduction for distributions to shareholders; and (2) shareholders would be taxed as if they received dividends from a corporation, although corporate shareholders could be eligible for the dividends-received deduction and non-corporate shareholders could be eligible for qualified dividend income treatment. This double taxation would increase the cost of investing in a Fund for shareholders and would make it more economical for shareholders to invest directly in debt obligations held by the Fund instead of investing indirectly in such debt obligations through the Fund.

Each Fund intends to invest all, or substantially all, of its assets in qualifying municipal debt obligations, the interest on which is generally exempt from the regular federal income tax and the federal AMT. For the Funds to pay tax-exempt distributions for any taxable year, at least 50% of the aggregate value of its assets at the close of each quarter of its taxable year must consist of municipal obligations that qualify under Section 103 of the Code. All or a portion of a tax-exempt distribution declared by the Funds may consist of income attributable to certain private activity bonds which are treated as preference items and must be taken into account in calculating an individual and corporate shareholder’s alternative minimum tax. Tax-exempt distributions may also be subject to state or local income taxes.



The Funds are designed to provide investors with current tax-exempt interest income. The Funds are not intended to constitute a balanced investment program and are not designed for investors seeking capital appreciation or maximum tax-exempt income irrespective of fluctuations in principal. Shares of the Funds may not be suitable for tax-exempt institutions, or for retirement plans qualified under Section 401 of the Code, H.R. 10 (Keogh) plans and individual retirement accounts because such plans and accounts are generally tax-exempt or tax-deferred and, therefore, would gain no additional benefit from the Fund's distributions being tax-exempt, and such distributions ultimately would be taxable to the beneficiaries when distributed to them. In addition, the Funds may not be appropriate investments for entities that are "substantial users" of facilities financed by private activity bonds or "related persons" thereof. "Substantial user" is defined under U.S. Treasury Regulations to include a non-exempt person who regularly uses a part of such facilities in his trade or business and whose gross revenues derived with respect to the facilities financed by the issuance of bonds are more than 5% of the total revenues derived by all users of such facilities, who occupies more than 5% of the usable area of such facilities, or for whom such facilities, or a part thereof, were specifically constructed, reconstructed or acquired. "Related persons" include certain related natural persons, affiliated corporations, a partnership and its partners and an S corporation and its shareholders.

The Short-Term Municipal Bond Fund is the successor to portfolio securities of a separately managed account held by an affiliate of the Advisor (the "Affiliated Account"), and the Short-Term Municipal Bond Fund has succeeded to the tax basis of the assets acquired from the Affiliated Account. As the Short-Term Municipal Bond Fund sells portfolio securities that were acquired from the Affiliated Account, any unrealized gain inherent in such securities at the time the Short-Term Municipal Bond Fund acquired such securities, along with any appreciation that occurred while the Fund held such securities, may be recognized by the Fund, and any such recognized gain will be distributed to Fund shareholders and will be taxable to them for federal income tax purposes. Accordingly, you may be taxed on appreciation that occurred before you purchased shares of such Fund, including appreciation that occurred prior to such Fund's acquisition of portfolio securities from the Affiliated Account.

Under the Foreign Account Tax Compliance Act ("FATCA"), the United States imposes a 30% withholding tax on certain payments made to certain foreign entities. This withholding tax could affect a Fund's return on its investments in foreign securities and affect a shareholder's return if the shareholder holds its Fund shares through a foreign intermediary subject to FATCA.

Each Fund is required to report to the IRS the cost basis of shares acquired by certain shareholders on or after January 1, 2012 ("covered shares") when the shareholder sells, exchanges or redeems such shares. These requirements do not apply to shares held through a tax-deferred arrangement, such as a 401(k) plan or an IRA, or to shares held by tax-exempt organizations, financial institutions, corporations (other than S corporations), banks, credit unions, and certain other entities and governmental bodies. Shares acquired before January 1, 2012 ("non-covered shares") are treated as if held in a separate account from covered shares. The Funds are not required to determine or report a shareholder's cost basis in non-covered shares and are not responsible for the accuracy or reliability of any information provided for non-covered shares.

The cost basis of a share is generally its purchase price adjusted for distributions, returns of capital, and other corporate actions. Cost basis is used to determine whether the sale, exchange or redemption of a share results in a gain or loss. If you sell, exchange or redeem covered shares of a Fund during any year, then the Fund will report the gain/loss, cost basis, and holding period of such shares to the IRS and you on Form 1099.

A cost basis method is the method by which a Fund determines which specific covered shares are deemed to be sold, exchanged or redeemed when a shareholder sells, exchanges or redeems less than its entire holding of Fund shares and has made multiple purchases of Fund shares on different dates at differing net

asset values. If a shareholder does not affirmatively elect a cost basis method, a Fund will use the average cost method, which averages the basis of all Fund shares in an account regardless of holding period, and shares sold, exchanged or redeemed are deemed to be those with the longest holding period first. Each shareholder may elect in writing (and not over the telephone) any alternate IRS-approved cost basis method to calculate the cost basis in its covered shares. The default cost basis method applied by the Fund or the alternate method elected by a shareholder may not be changed after the settlement date of a sale, exchange or redemption of Fund shares.

If you hold Fund shares through a financial intermediary (or another nominee), please contact that broker or nominee with respect to the reporting of cost basis and available elections for your account.

You are encouraged to consult your tax adviser regarding the application of these cost basis reporting rules and, in particular, which cost basis calculation method you should elect.

### Capital Loss Carryovers

If a Fund incurs net capital losses in future taxable years, those losses will be carried forward to one or more subsequent taxable years without expiration, and the losses will retain their character as either short-term or long-term.

## **MANAGEMENT OF THE COMPANY**

Under the laws of the State of Wisconsin, the business and affairs of the Funds are managed under the direction of the Board. The Board is responsible for acting on behalf of the shareholders.

The Company does not normally hold shareholders' meetings except when required by the 1940 Act or the Wisconsin Business Corporation Law (WBCL). Under the 1940 Act, shareholder meetings are required to vote on director nominees, to approve an investment advisory agreement and to change fundamental investment policies. Under the Company's By-Laws, the Company is not required to hold an annual meeting in any year in which the 1940 Act does not require a shareholder vote to elect directors, approve the Company's investment advisory agreement, ratify the independent auditors or approve the Company's distribution agreement.

### Board Leadership Structure

The Board is comprised of four Independent Directors – John W. Feldt, Frederick P. Stratton, Jr., Marlyn J. Spear and G. Frederick Kasten, Jr. – and one Interested Director – Cory L. Nettles. Mr. Kasten, an Independent Director, serves as Chairman of the Board. The Board has established two standing committees – the Audit Committee and the Nominating Committee. Ms. Spear, an Independent Director, serves as the Chair of the Audit Committee. The Audit Committee and the Nominating Committee are each comprised entirely of Independent Directors. In accordance with the fund governance standards prescribed by the SEC under the 1940 Act, the Independent Directors on the Nominating Committee select and nominate all candidates for Independent Director positions.

Each Director was appointed to serve on the Board because of his or her experience, qualifications, attributes and/or skills as set forth in the subsection "Director Qualifications," below. The Board reviews its leadership structure regularly. The Board believes that its leadership structure is appropriate and effective in light of the size of the Company, the nature of its business and industry practices.

The Board's role is one of oversight rather than management. The Board's committee structure assists with this oversight function. The Board's oversight extends to the Funds' risk management processes. Those

processes are overseen by Fund officers, including the President, Treasurer, Secretary and Chief Compliance Officer (“CCO”), who regularly report to the Board on a variety of matters at Board meetings.

The Advisor reports to the Board, on a regular and as-needed basis, on actual and possible risks affecting the Funds and the Company as a whole. The Advisor reports to the Board on various elements of risk, including investment, credit, liquidity, valuation, operational and compliance risks, as well as any overall business risks that could impact the Funds.

The Board has appointed the CCO who reports directly to the Independent Directors, meets quarterly in executive session with the Independent Directors and who participates in the Board’s regular meetings. In addition, the CCO presents an annual report to the Board in accordance with the Funds’ compliance policies and procedures. The CCO, together with the other Fund officers, regularly discusses risk issues affecting the Company during Board meetings. The CCO also provides updates to the Board on the operation of the Funds’ compliance policies and procedures and on how these procedures are designed to mitigate risk. Finally, the CCO and/or representatives of the Advisor’s legal department report to the Board in the event any material risk issues arise in between Board meetings.

#### Directors and Officers

Directors and officers of the Company, together with information as to their principal business occupations during the last five years and other information, are shown in the following table. Each officer and Director holds the same positions with the Company and each Fund.

<b>Name, Address and Age (as of 12/31/14)</b>	<b>Position(s) Held with the Company</b>	<b>Term of Office and Length of Time Served</b>	<b>Principal Occupation(s) During Past 5 Years</b>	<b>Number of Portfolios in Fund Complex Overseen by Director</b>	<b>Other Directorships Held by Director During Past 5 Years</b>
<b>Independent Directors</b>					
G. Frederick Kasten, Jr. c/o Robert W. Baird & Co. Incorporated 777 East Wisconsin Ave Milwaukee, WI 53202 Age: 75	Independent Director and Chairman	Indefinite; Since September 2000	Retired; Chairman, the Advisor (January 2000-December 2005); Chairman and CEO, the Advisor (January 1998-January 2000); President, Chairman and CEO, the Advisor (June 1983-January 1998); President, the Advisor (January 1979-January 1983).	11	Director of Regal-Beloit Corporation, a manufacturing company (1995-2011).
John W. Feldt c/o Robert W. Baird & Co. Incorporated 777 East Wisconsin Ave Milwaukee, WI 53202 Age: 72	Independent Director	Indefinite; Since September 2000	Retired; Senior Vice President-Finance, University of Wisconsin Foundation (1985-2006); Vice President-Finance, University of Wisconsin Foundation (1980-1985); Associate Director, University of Wisconsin Foundation (1967-1980).	11	Director of Thompson IM Funds, Inc., a mutual fund complex (3 portfolios) , since 1987; Trustee of Nakoma Mutual Funds, a mutual fund complex (2006-2011).
Frederick P. Stratton, Jr. c/o Robert W. Baird & Co. Incorporated 777 East Wisconsin Ave Milwaukee, WI 53202 Age: 75	Independent Director	Indefinite; Since May 2004	Retired; Chairman Emeritus, Briggs & Stratton Corporation, a manufacturing company, since 2003; Chairman of the Board, Briggs & Stratton Corporation (2001-2002); Chairman and CEO, Briggs & Stratton Corporation (1986-2001).	11	Director of Weyco Group, Inc., a men's footwear distributor, since 1976; Director of Wisconsin Energy Corporation and its subsidiaries, Wisconsin Electric Power Company and Wisconsin Gas LLC (1987-2012).

<b>Name, Address and Age (as of 12/31/14)</b>	<b>Position(s) Held with the Company</b>	<b>Term of Office and Length of Time Served</b>	<b>Principal Occupation(s) During Past 5 Years</b>	<b>Number of Portfolios in Fund Complex Overseen by Director</b>	<b>Other Directorships Held by Director During Past 5 Years</b>
Marlyn J. Spear, CFA c/o Robert W. Baird & Co. Incorporated 777 East Wisconsin Ave Milwaukee, WI 53202 Age: 61	Independent Director	Indefinite; Since January 2008	Chief Investment Officer, Building Trades United Pension Trust Fund, since July 1989; Investment Officer, Northwestern Mutual Financial Network (1988-1989); Assistant Vice-President, Firststar Trust Company (1978-1987); Financial Analyst, Harco Holdings, Inc. (1976-1978).	11	Management Trustee of AFL-CIO Housing Investment Trust, a mutual fund complex (1 portfolio), since 1995.

---

**Interested Director**

Cory L. Nettles* Generation Growth Capital, Inc. 411 East Wisconsin Ave Suite 1710 Milwaukee, WI 53202 Age: 44	Interested Director	Indefinite; Since January 2008	Managing Director, Generation Growth Capital, Inc., a private equity fund, since March 2007; Of Counsel, Quarles & Brady LLP, a law firm, since January 2005; Secretary, Wisconsin Department of Commerce (January 2003 – January 2005).	11	Director of Weyco Group, Inc., a men's footwear distributor since _____; Director of Associated Banc-Corp, since 2013; Director of PrivateBank, a financial institution (2007-2010).
--	------------------------	--------------------------------------	---	----	--

---

\* Mr. Nettles is considered an "interested person" of the Company (as defined in the 1940 Act) because of his association with the law firm, Quarles & Brady LLP, which provides legal services to the Advisor. The legal services that Quarles & Brady LLP has provided to the Advisor include litigation, real estate, trademark and miscellaneous securities related matters that did not relate to the Company or the Funds. The Advisor has invested in and may in the future invest in private equity funds managed by Generation Growth Capital, Inc., a company of which Mr. Nettles is affiliated, through its division, Baird Capital.

<b>Name, Address and Age (as of 12/31/14)</b>	<b>Position(s) Held with the Company</b>	<b>Term of Office and Length of Time Served</b>	<b>Principal Occupation(s) During Past 5 Years</b>
<b>Officers</b>			
Mary Ellen Stanek 777 East Wisconsin Ave Milwaukee, WI 53202 Age: 58	President	Re-elected by Board annually; Since September 2000	Managing Director, the Advisor, and Chief Investment Officer, Baird Advisors, a department of the Advisor, since March 2000; Director, Baird Kailash Group, LLC since December 2013.
Charles B. Groeschell 777 East Wisconsin Ave Milwaukee, WI 53202 Age: 61	Vice President	Re-elected by Board annually; Since January 2010	Managing Director, the Advisor, and Senior Portfolio Manager, Baird Advisors, a department of the Advisor, since February 2000.
Angela M. Palmer 777 East Wisconsin Ave Milwaukee, WI 53202 Age: 43	Chief Compliance Officer and AML Compliance Officer	Re-elected by Board annually; Since March 2014	Chief Compliance Officer, the Advisor, since March 2014; Anti-Money Laundering Compliance Officer since May 2015; Director, the Advisor since July 2014; Senior Vice President, the Advisor March 2014-July 2014; Chief Compliance Officer RIAs US, BMO Financial Group from January 2013-March 2014; Chief Compliance Officer Institutional RIAs from March 2012-January 2013; Vice President BMO Harris Bank N.A. from July 2011-March 2014; Chief Compliance Officer, Taplin, Canida & Habacht, LLC from December 2008-March 2014; Chief Compliance Officer and Vice President M&I Investment Management Corp. from June 2006-May 2012; Assistant Secretary, M&I Investment Management Corp. from April 2010-May 2012; Vice President, Marshall & Ilsley Trust Company N.A. from June 2006-August 2012.
Terrance P. Maxwell 777 East Wisconsin Ave Milwaukee, WI 53202 Age: 54	Treasurer	Re-elected by Board annually; Since March 2015	Chief Financial Officer, the Advisor, since March 2015; Manager, Greenhouse Funds, LP, an affiliate of the Advisor, since April 2014; Trustee, Investors Real Estate Trust, since November 2013; Director of Corporate Development and Strategic Investment, the Advisor, from May 2014 – March 2015; Lecturer at University of Wisconsin – Madison from August 2006 – May 2010 and August 2011 – May 2014; consultant and Director of Flatirons Solutions, a portfolio company of Baird Capital Partners, from April 2011 – June 2012.
Charles M. Weber 777 East Wisconsin Ave Milwaukee, WI 53202 Age: 51	Secretary	Re-elected by Board annually; Since September 2005	Senior Associate General Counsel, the Advisor, since January 2013; Managing Director, the Advisor, since January 2009; Chief Compliance Officer and Secretary, Baird Kailash Group, LLC, since July 2013; Associate General Counsel, the Advisor (July 2005-December 2012).

<b>Name, Address and Age (as of 12/31/14)</b>	<b>Position(s) Held with the Company</b>	<b>Term of Office and Length of Time Served</b>	<b>Principal Occupation(s) During Past 5 Years</b>
Peter J. Hammond 777 East Wisconsin Ave Milwaukee, WI 53202 Age: 51	Vice President	Re-elected by Board annually; Since August 2012	Senior Vice President, the Advisor since March 2012; Vice President, Baird Kailash Group, LLC, since July 2013; Executive VP and Chief Administrative Officer, UMB Fund Services (September 1996 to March 2012).
Dustin J. Hutter 777 East Wisconsin Ave Milwaukee, WI 53202 Age: 38	Assistant Treasurer	Re-elected by Board annually; Since February 2011	Director of Reporting and Analysis, Capital Markets Finance, since February 2013; Senior Vice President, the Advisor, since January 2011; Treasurer, Baird Kailash Group, LLC since July 2013; First Vice President, the Advisor (January 2008-December 2010); Vice President, the Advisor (January 2006-December 2007); Assistant Controller, the Advisor (January 2006-January 2013).
Andrew D. Ketter 777 East Wisconsin Ave Milwaukee, WI 53202 Age: 40	Assistant Secretary	Re-elected by Board annually; Since February 2011	Associate General Counsel, the Advisor, since September 2010; Director, the Advisor, since July 2014, Senior Vice President, the Advisor, (January 2014-June 2014); First Vice President, the Advisor (September 2010-December 2013); Associate, Quarles & Brady LLP, a law firm (September 2002-August 2010).

### Director Qualifications

The following is a brief discussion of the experience, qualifications, attributes and/or skills that led to the Board's conclusion that each individual identified below is qualified to serve as a Director of the Company.

*John W. Feldt.* Mr. Feldt has served as a Director of the Company since September 2000. He serves as an independent director of Thompson IM Funds, Inc., a mutual fund complex with three portfolios. He also served as an independent trustee of Nakoma Mutual Funds, a mutual fund complex with one portfolio, from March 2006 to November 2011. While employed with the University of Wisconsin Foundation, Mr. Feldt served as Senior Vice President-Finance from 1985 to 2006, as Vice President-Finance from 1980 to 1985 and as Associate Director from 1967 to 1980. Through his experience as a director and trustee of mutual funds and his business experience, Mr. Feldt is experienced with financial, accounting, regulatory and investment matters.

*Frederick P. Stratton, Jr.* Mr. Stratton has served as a Director of the Company since May 2004. He also serves as an independent director of Weyco Group, Inc., a men's footwear distributor. He served as an independent director of Wisconsin Energy Corporation and its subsidiaries, Wisconsin Electric Power Company and Wisconsin Gas LLC from 1987 to 2012. Mr. Stratton has served as Chairman Emeritus of Briggs & Stratton Corporation, a manufacturing company, since 2003. At Briggs & Stratton Corporation, he also served as Chairman from 2001 to 2002 and Chairman and CEO from 1986 to 2001. While at Briggs & Stratton Corporation, Mr. Stratton had management responsibilities for the company's retirement trust assets. In addition, prior to joining Briggs & Stratton Corporation, he spent eight years as an investment analyst and was a CFA charterholder. Through his board experience with mutual funds and public companies and his business experience, Mr. Stratton is experienced with financial, accounting, regulatory and investment matters.

*Marlyn J. Spear, CFA.* Ms. Spear has served as a Director of the Company since January 2008. She serves as Management Trustee of AFL-CIO Housing Investment Trust, a mutual fund complex with one portfolio, since 1995 and as Chief Investment Officer of the Building Trades United Pension Trust Fund since 1989. She served as Investment Officer of Northwestern Mutual Financial Network from 1988 to 1989, as Assistant Vice President of Firststar Trust Company from 1978 to 1987 and as Financial Analyst of Harco Holdings, Inc. from 1976 to 1978. Ms. Spear has earned the Chartered Financial Analyst designation. Through her experience as a director and trustee of mutual funds and her business experience, Ms. Spear is experienced with financial, accounting, regulatory and investment matters.

*G. Frederick Kasten, Jr.* Mr. Kasten has served as a Director and Chairman of the Company since September 2000. He also served as an independent director of Regal-Beloit Corporation, a manufacturing company from 1995 to 2011. Mr. Kasten has held numerous positions with the Advisor including Chairman from 2000 to 2005, Chairman and CEO from 1998 to 2000, President, Chairman and CEO from 1983 to 1998, and President from 1979 to 1983. Through his board experience with mutual funds and public companies and his business experience, Mr. Kasten is experienced with financial, accounting, regulatory and investment matters.

*Cory L. Nettles.* Mr. Nettles has served as a Director of the Company since January 2008. He serves as an independent director of Weyco Group, Inc., a men's footwear distributor, and Associated Banc-Corp. He previously served as a director of The PrivateBank, a financial institution from January 2007 to October 2010. Mr. Nettles has served as Managing Director of Generation Growth Capital, Inc., a private equity fund, since 2007. He has been Of Counsel at Quarles & Brady LLP, a law firm, since 2005. Mr. Nettles served as Secretary of the Wisconsin Department of Commerce from 2003 to 2005 and as a senior advisor to Baird Capital, a division of the Advisor from February 2011 to January 2012. Through his experience with investment funds and public companies, his employment experience and his legal training and practice, Mr. Nettles is experienced with financial, accounting, legal, regulatory and investment matters.

#### Board Committees

The Board has two standing committees — an Audit Committee and a Nominating Committee. The Audit Committee is responsible for advising the full Board with respect to accounting, auditing and financial matters affecting the Company and meets at least semi-annually. During the fiscal year ended December 31, 2014, the Audit Committee met two times. John W. Feldt, Marlyn J. Spear and Frederick P. Stratton, Jr., all of whom are Independent Directors, comprise the Audit Committee.

The Nominating Committee is responsible for seeking and reviewing candidates for consideration as nominees to serve as Directors of the Company and meets as often as it deems necessary. During the fiscal year ended December 31, 2014, the Nominating Committee met once. John W. Feldt, Marlyn J. Spear and Frederick P. Stratton, Jr., all of whom are Independent Directors, comprise the Nominating Committee. The Nominating Committee will consider properly qualified candidates for the Board submitted by shareholders. Shareholders who wish to recommend a Director nominee may do so by submitting the appropriate information about the candidate to the Company's Secretary.

A Valuation Committee, which is not comprised of members of the Board, was established by the Board. The Valuation Committee is responsible for (1) monitoring the valuation of Fund securities and other investments; and (2) as required, determining the fair value of securities and other investments of the Funds when market prices are not readily available or are deemed to be inaccurate or prices are not otherwise provided by a third-party pricing service approved by the Board or an independent dealer, after considering all relevant factors. The Valuation Committee's fair value determinations are subsequently reported to the Board. The Valuation Committee meets as necessary when a price is not readily available. During the fiscal year ended December 31, 2014, the Valuation Committee met five times with respect to the Funds.



## Board Compensation

With respect to fiscal year 2014, each Director received an annual fee of \$65,000, plus \$6,250 per Board meeting attended (\$2,500 per meeting attended by telephone). In addition, each Director is reimbursed by the Company for travel and other expenses incurred in connection with attendance at such meetings. Committee members do not receive additional compensation for committee meetings attended. Officers of the Funds receive no compensation or expense reimbursement from the Company or the Advisor for serving in such capacity, except that the Advisor pays compensation to Angela M. Palmer for her services as Chief Compliance Officer of the Funds. Neither the Company nor the Funds maintain any deferred compensation, pension or retirement plans, and no pension or retirement benefits are accrued as part of Company or Fund expenses. Pursuant to the Administration Agreement discussed under “Investment Advisory and Other Services” in this SAI, the Advisor assumes and pays all compensation payable to the Directors for overseeing the Funds. Accordingly, no payments are estimated to be made by the Funds to the directors for the current fiscal year ending December 31, 2015.

## Board Ownership of the Funds

As of the date of this SAI, no Director of the Company beneficially owned shares of the Funds.

As of December 31, 2014, the Directors beneficially owned the following amounts (by dollar range) in the Fund Complex (*Note: the Directors only own Institutional Class shares*):

<u>Name of Director</u>	<u>Aggregate Dollar Range of Equity Securities Beneficially Owned in All Registered Investment Companies Overseen by Director in Family of Investment Companies</u>
John W. Feldt	Over \$100,000
Marlyn J. Spear	Over \$100,000
Frederick P. Stratton, Jr.	Over \$100,000
G. Frederick Kasten, Jr.	Over \$100,000
Cory L. Nettles	Over \$100,000

## CONTROL PERSONS AND PRINCIPAL SHAREHOLDERS

A principal shareholder is any person who owns of record or beneficially 5% or more of the outstanding shares of the Fund. A control person is one who owns, beneficially or through controlled companies, more than 25% of the voting securities of the Fund or who acknowledges the existence of control. Shareholders with a controlling interest could affect the outcome of proxy voting or the direction of the management of the Fund.

As of the date of this SAI, the officers and Directors of the Company did not own any shares of the Funds.

## PORTFOLIO TRANSACTIONS

Subject to the general supervision of the Board, the Advisor is responsible for, makes decisions with respect to, and places orders for all purchases and sales of portfolio securities for each Fund.

Fixed income debt obligations purchased and sold by the Funds are generally traded in the over-the-counter market on a net basis (*i.e.*, without commission) through dealers, or otherwise involve transactions directly with the issuer of an instrument. The cost of debt obligations purchased from underwriters includes an underwriting commission or concession, and the prices at which debt obligations are purchased from and sold to dealers include a dealer’s mark-up or mark-down.

The Funds may participate, if and when practicable, in bidding for the purchase of portfolio debt obligations directly from an issuer in order to take advantage of the lower purchase price available to members of a bidding group. A Fund will engage in this practice, however, only when the Advisor, in its sole discretion, believes such practice to be in the Fund's interests.

Equity securities are generally bought and sold in brokerage transactions placed on U.S. stock exchanges or in the over-the-counter market in exchange for negotiated brokerage commissions. Accordingly, the cost of transactions may vary among different brokers. With respect to over-the-counter transactions, the Advisor will normally deal directly with dealers who make a market in the securities involved except in those circumstances where better prices and execution are available elsewhere.

The investment advisory agreement between the Company and the Advisor provides that, in executing portfolio transactions and selecting brokers or dealers, the Advisor will seek to obtain the most favorable prices and at reasonable commission rates. In assessing the best overall terms available for any transaction, the Advisor shall consider factors it deems relevant, including the breadth of the market in the debt obligation, the price of the debt obligation, the financial condition and execution capability of the broker or dealer, and the reasonableness of the commissions, if any, both for the specific transaction and on a continuing basis. In addition, as permitted by Section 28(e) of the Securities Exchange Act of 1934, the Agreement authorizes the Advisor to cause the Funds to pay commissions for brokerage and research services, a practice commonly referred to as "soft dollars." The Advisor has adopted a soft dollar policy requiring it to undertake a three-step analysis to determine whether a research product or service falls within the Section 28(e) safe harbor. First, the Advisor must determine whether the product or service constitutes eligible research services under Section 28(e). Second, the Advisor must determine whether the product or service actually provides lawful and appropriate assistance in the performance of the Advisor's investment decision-making responsibilities. Third, the Advisor must make a good faith determination that the amount of the commissions paid by the Funds and other clients of the Advisor is reasonable in light of the value of the research and brokerage products and services provided by the broker-dealer effecting the transaction.

The types of research services that generally are considered eligible under Section 28(e) and that provide lawful and appropriate assistance to the Advisor in performing its investment decision-making responsibilities may consist of advice, either directly or through publications or writings, as to the value of securities or the advisability of purchasing or selling securities; or analyses and reports concerning issuers, industries, securities, economic factors and trends, portfolio strategy, as well as political factors and other topics related to securities and financial markets. Typical items that qualify as eligible research include: research reports analyzing the historical or prospective performance of a particular company or stock; discussions with research analysts regarding the advisability of investing in stock; meetings with corporate executives arranged by a broker-dealer to obtain oral reports on the performance of a company; seminars and conferences to the extent they provide substantive content relating to issuers, industries or securities; portfolio analysis software, financial, trade, industry and investment-related publications marketed to a narrow audience; and market, economic, political, company-specific and other data providing substantive content. The research services may be proprietary research offered by the broker or dealer executing a trade or research offered by third parties through the executing broker or dealer. The Advisor does not currently use soft dollars for the Funds. There are no directed brokerage arrangements involving the use of commissions for the Funds in exchange for research services. In considering dealers through which the Advisor will buy or sell fixed income securities for the Funds, the Advisor will select the dealers that provide the best price and execution. However, the Advisor may place a trade for a fixed income debt obligation with a dealer that provides research services to the Advisor so long as the price to be paid by the dealer is not worse than prices provided by other dealers for the same debt obligation.

Supplementary research information so received is in addition to, and not in lieu of, services required to be performed by the Advisor and does not reduce the advisory fees payable to it by the Funds. The Board will periodically review the commissions paid by the Funds to consider whether the commissions paid over representative periods of time appear to be reasonable in relation to the benefits inuring to the Funds. Research services furnished by firms through which a Fund effects its securities transactions may be used by the Advisor in servicing all of its accounts; not all of such services may be used by the Advisor in connection with the Fund. It is possible that certain of the supplementary research or other services received will primarily benefit one or more other accounts for which investment discretion is exercised. Conversely, a Fund may be the primary beneficiary of the research or services received as a result of portfolio transactions effected for such other account(s).

Brokerage may not be allocated based on the sale of Fund shares. The Board, including a majority of the Independent Directors, has adopted policies and procedures designed to ensure that the selection of brokers is not influenced by considerations about the sale of Fund shares.

Portfolio debt obligations will not be purchased from or sold to (and savings deposits will not be made in and repurchase and reverse repurchase agreements will not be entered into with) the Advisor, or an affiliated person of the Advisor (as such term is defined in the 1940 Act), acting as principal. However, pursuant to SEC rules, the Funds may engage the Advisor or an affiliate of the Advisor to act as broker in connection with purchases or sales of portfolio debt obligations effected on an agency basis. To date, the Funds have not done so. The Funds will not purchase debt obligations during the existence of any underwriting or selling group relating thereto of which the Advisor or an affiliated person is a member, except to the extent permitted by the SEC. The Funds may purchase debt obligations through underwritings in which U.S. Bank N.A. or an affiliate is a participant in accordance with the Funds' affiliated underwriting procedures, which generally require that the participating U.S. Bank affiliate be carved out from any compensation related to an affiliated Fund participation in the offering.

The Advisor manages numerous accounts in addition to the Funds and many of those accounts hold and invest in the same debt obligations as the Funds. The Advisor allocates investment opportunities across the Funds and its other similarly managed accounts in a fair and equitable manner, with no account(s) being favored over others. In making investment allocations, the Advisor considers the clients' investment goals and restrictions, uninvested cash, sector and issuer diversification, anticipated cash flows, risk tolerances, portfolio size and other relevant factors. The Funds generally do not invest in initial public offerings of equity securities, so allocations of new issues are usually not required.

The Advisor may, when appropriate, aggregate purchases or sales of debt obligations and allocate such trades among multiple client accounts, including the Funds. The Advisor will aggregate orders when it believes it will be advantageous to do so, such as the possibility of obtaining more favorable execution and prices. However, in some instances, bunching an order for a Fund with orders for other client accounts may adversely affect the price paid or received by the Fund or the size of the position obtained or sold by the Fund because the Fund's order is being shared with other accounts. Aggregated orders that can only be partially filled will typically be allocated on a pro rata basis, subject to de minimis requirements. Each account participating in an aggregated order will receive the same average price.

## **INVESTMENT ADVISORY AND OTHER SERVICES**

### Advisory Services

Pursuant to an Investment Advisory Agreement (the "Advisory Agreement"), Robert W. Baird & Co. Incorporated ("Baird"), 777 East Wisconsin Avenue, Milwaukee, WI 53202, furnishes continuous

investment advisory services and management to the Funds. The Advisor is an investment advisory and brokerage firm formed in the State of Wisconsin on December 29, 1919.

Baird is owned indirectly by its employees and employees of Baird Kailash Group, LLC, an affiliate of Baird (“BKG”) through several holding companies. Baird is owned directly by Baird Financial Corporation (“BFC”). BFC is, in turn, owned by Baird Holding Company (“BHC”). BHC is owned by Baird Financial Group, Inc. (“BFG”), which is the ultimate parent company of Baird. Employees of Baird and BKG own substantially all of the outstanding stock of BFG.

The Advisory Agreement is required to be approved annually (a) by the vote of a majority of the Independent Directors, cast in person at a meeting called for the purpose of voting on such approval, and (b) either by the full Board or by the vote of the shareholders. The Advisory Agreement with respect to each Fund was approved by the Independent Directors on August 27, 2015. The Advisory Agreement terminates in the event of assignment and generally may be terminated by either party if certain conditions are met, without penalty, on a 60-day notice. The Advisory Agreement will continue in effect, unless sooner terminated, for an initial two-year term and successive one-year periods so long as it is approved annually. In the Advisory Agreement, the Advisor has agreed to pay all expenses incurred by it in connection with its advisory activities. These expenses do not include the cost of debt obligations and other investments purchased or sold for a Fund and do not include brokerage commissions and any other transaction charges. Brokerage commissions and other transaction charges are included in the cost basis of the debt obligations and other investments.

As compensation for its advisory services under the Advisory Agreement, the Funds pay to the Advisor a monthly management fee at the annual rate of 0.25% of the average daily NAV of the applicable Fund. The agreement may only be terminated prior to the end of this term by or with the consent of the Board of Directors. From time to time, the Advisor may voluntarily waive all or a portion of its management fee for a Fund.

In addition to the Advisory Agreement, the Company, on behalf of the Funds, has entered into an Administration Agreement (the “Administration Agreement”) with the Advisor. Under the Administration Agreement, the Advisor renders all administrative and supervisory services to the applicable Fund. The Advisor oversees the maintenance of all books and records with respect to the Fund’s securities transactions and the Fund’s book of accounts in accordance with all applicable federal and state laws and regulations. The Advisor also arranges for the preservation of journals, ledgers, corporate documents, brokerage account records and other records which are required pursuant to Rule 31a-1 under the 1940 Act. The Advisor is also responsible for the equipment, staff, office space and facilities necessary to perform its obligations. The Advisor has delegated some of its administrative and other responsibilities to U.S. Bancorp Fund Services, LLC (“USBFS”) and is responsible for paying all fees and expenses of USBFS. Under the Administration Agreement, the Advisor assumes and pays all expenses of the applicable Fund, excluding management fees, borrowing costs, commissions and other costs directly related to portfolio securities transactions and extraordinary or non-recurring expenses. Each Fund also pays expenses which it is authorized to pay pursuant to Rule 12b-1 under the 1940 Act.

Pursuant to the Administration Agreement, the Advisor receives a fee that is paid monthly at an annual rate of 0.05% of the applicable Fund’s average daily net assets.

The Advisor may act as an investment advisor and administrator to other persons, firms, or corporations (including investment companies), and may have numerous advisory clients in addition to the Funds.

### Proxy Voting Policies

The Funds generally do not vote proxies because they invest in bonds and other fixed income debt obligations which are not entitled to vote. In the event a Fund invests in voting securities, the Board has adopted proxy voting policies and procedures that delegate the authority to vote proxies to the Advisor, subject to the supervision of the Board. The Board has also authorized the Advisor to retain a third party proxy voting service, such as ISS, to provide recommendations on proxy votes. The Advisor's proxy voting policies and procedures provide that the Advisor will typically vote proxies in accordance with the recommendations made by ISS, and in the best interest of clients and Fund shareholders. However, because ISS' guidelines do not address all potential voting issues and do not necessarily correspond to the Advisor's opinions, there may be instances where the Advisor may not vote strictly according to the ISS' guidelines. In such a case, the Advisor submits the matter to its proxy voting committee.

In situations where the Advisor's interests conflict, or appear to conflict, with client interests, the proxy voting committee will take one of the following steps to resolve the conflict:

- Vote the securities in accordance with a pre-determined policy based upon the recommendations of an independent third party, such as ISS;
- Refer the proxy to the client or to a fiduciary of the client for voting purposes;
- Vote the securities in accordance with the best interest of clients, as determined in good faith by the committee, without consideration of any benefit to the Advisor or its affiliates; or
- If the securities are held by a Fund, disclose the conflict to the Board and obtain the Fund's direction as to how to vote the proxies (which shall be determined by a majority of the Independent Directors).

Each Fund's proxy voting record for the most recent 12-month period ended June 30, if applicable, will be available without charge, either upon request, by calling toll free, 1-866-44BAIRD, or by accessing the Funds' website at [www.bairdfunds.com](http://www.bairdfunds.com), or both; and by accessing the SEC's website at <http://www.sec.gov>.

### Code of Ethics

The Company, the Advisor and the Distributor have adopted a joint written Code of Ethics under Rule 17j-1 of the 1940 Act. The Code of Ethics governs the personal securities transactions of directors, officers and employees who may have access to current trading information of the Funds. The Code of Ethics permits such persons to invest in securities for their personal accounts, including securities that may be purchased or held by the Funds, subject to certain restrictions. The Code of Ethics includes pre-clearance, reporting and other procedures to monitor personal transactions and ensure that such transactions are consistent with the best interests of the Funds.

### Fund Sub-Administration

Pursuant to a Sub-Administration Agreement between USBFS and the Advisor, USBFS provides administrative personnel and services (including blue-sky services) to the Company and the Funds. Administrative services include, but are not limited to, providing equipment, telephone facilities, various personnel, including clerical and supervisory, and computers as is necessary or beneficial to provide compliance services to the Funds and the Company. All fees and expenses due to USBFS under the Sub-Administration Agreement are paid by the Advisor, not the Funds. USBFS is an affiliated person of an

affiliated person of the Company due to the affiliation with U.S. Bank National Association described below.

#### Custodian

U.S. Bank National Association (“U.S. Bank”), 1555 N. Rivercenter Drive, Suite 302, Milwaukee, Wisconsin 53212, serves as custodian of the Funds’ assets. U.S. Bank is currently considered an “affiliated person” of the Company for purposes of the 1940 Act as a result of certain of U.S. Bank’s fiduciary accounts for which it has investment authority and/or voting authority collectively acquiring 5% or more of the shares of the Baird Aggregate Bond Fund. Under the Custody Agreement between U.S. Bank and the Funds (the “Custody Agreement”), U.S. Bank has agreed to (i) maintain separate accounts in the name of the Funds; (ii) make receipts and disbursements of money on behalf of the Funds; (iii) collect and receive all income and other payments and distributions on account of a Fund’s portfolio investments; (iv) respond to correspondence from shareholders, security brokers and others relating to its duties; and (v) make periodic reports to the Company concerning the Funds’ operations. U.S. Bank may, at its own expense, open and maintain a custody account or accounts on behalf of the Funds with other banks or trust companies, provided that U.S. Bank shall remain liable for the performance of all of its duties under the Custody Agreement notwithstanding any delegation. U.S. Bank and USBFS are affiliates. U.S. Bank and its affiliates may participate in revenue sharing arrangements with service providers of mutual funds in which the Funds may invest. All fees and expenses due to U.S. Bank under the Custody Agreement are paid by the Advisor, not the Funds.

#### Transfer Agent

USBFS, 615 East Michigan Street, Milwaukee, Wisconsin 53202, serves as transfer agent and dividend disbursing agent for the Funds under a Transfer Agent Servicing Agreement (the “Transfer Agent Servicing Agreement”). As transfer and dividend disbursing agent, USBFS has agreed to (i) issue and redeem shares of the Funds; (ii) make dividend payments and other distributions to shareholders of the Funds; (iii) respond to correspondence by Fund shareholders and others relating to its duties; (iv) maintain shareholder accounts; and (v) make periodic reports to the Funds. All fees and expenses due to USBFS under the Transfer Agent Servicing Agreement are paid by the Advisor, not the Funds.

#### Fund Accounting

In addition, the Funds have entered into a Fund Accounting Servicing Agreement (the “Accounting Agreement”) with USBFS pursuant to which USBFS has agreed to maintain the financial accounts and records of the Funds in compliance with the 1940 Act and to provide other accounting services to the Funds.

#### Financial Intermediaries

From time to time, the Advisor or Distributor may pay, directly or indirectly, amounts to financial intermediaries that provide transfer-agent type and/or other administrative services relating to the Funds to their customers or other persons who beneficially own interests in the Funds, such as participants in 401(k) plans. These services may include, among other things, sub-accounting services, transfer agent-type services, answering inquiries relating to the Funds, transmitting, on behalf of the Funds, proxy statements, annual reports, updated prospectuses and other communications regarding the Funds, and related services as the Funds or the intermediaries’ customers or such other persons may reasonably request.

## PORTFOLIO MANAGERS

### Other Accounts Managed by Portfolio Managers of the Funds

As described in the Prospectus under “The Investment Management Team,” each portfolio manager listed below is jointly responsible for the day-to-day management of each Fund and is jointly responsible for the day-to-day management of the other accounts set forth in the following table.

The following provides information regarding other accounts managed by the portfolio managers as of June 30, 2015.

### **Other Accounts Managed by the Portfolio Managers**

<b>Category of Account</b>	<b>Total Number of Accounts Managed</b>	<b>Total Assets in Accounts Managed</b>	<b>Number of Accounts for which Advisory Fee is Based on Performance</b>	<b>Assets in Accounts for which Advisory Fee is Based on Performance</b>
<b><u>Duane A. McAllister</u></b>				
Other Registered Investment Companies	1	\$1.719 billion	0	\$0
Other Pooled Investment Vehicles	0	\$0	0	\$0
Other Accounts	129	\$27.529 billion	1	\$1.1 billion
<b><u>Erik R. Schleicher</u></b>				
Other Registered Investment Companies	1	\$1.719 billion	0	\$0
Other Pooled Investment Vehicles	0	\$0	0	\$0
Other Accounts	129	\$27.529 billion	1	\$1.1 billion
<b><u>Joseph J. Czechowicz</u></b>				
Other Registered Investment Companies	1	\$1.719 billion	0	\$0
Other Pooled Investment Vehicles	0	\$0	0	\$0
Other Accounts	129	\$27.529 billion	1	\$1.1 billion

The Advisor and its individual portfolio managers advise multiple accounts for numerous clients. In addition to the Funds, these accounts may include other mutual funds managed on a subadvisory basis, separate accounts, collective trusts, and a portion of a state 529 education savings plan portfolio. The Advisor manages potential conflicts of interest between a Fund and other types of accounts through trade allocation policies and oversight by the Advisor’s investment management departments and compliance department. Allocation policies are designed to address potential conflicts of interest in situations where two or more Funds and/or other accounts participate in investment transactions involving the same securities.

### Compensation of Portfolio Managers

The Advisor compensates portfolio managers with a base salary and an annual incentive bonus. A portfolio manager's base salary is generally a fixed amount based on level of experience and responsibilities. A portfolio manager's bonus is determined primarily by pre-tax investment performance of the accounts, including the Funds, and the revenues and overall profitability of the Advisor. A Fund's performance is measured relative to the performance of the benchmark index listed in the Funds' prospectus and is measured on a one-three-five-year basis (or such shorter time as the portfolio manager has managed a Fund), as applicable, with greater weight given to long-term performance. Portfolio managers may own and may be offered an opportunity to purchase or sell common stock in the Advisor, BHC, BFC, or BFG. Portfolio managers may also own and may be offered an opportunity to purchase or sell shares in private securities offerings sponsored by the Advisor.

### Ownership of Fund Shares by Portfolio Managers

As of the date of this SAI, the portfolio managers do not own any shares of the Funds.

### **DISTRIBUTOR**

Robert W. Baird & Co. Incorporated also serves as the principal distributor for shares of the Funds pursuant to a Distribution Agreement with the Company dated September 26, 2000, as amended (the "Distribution Agreement"). The Distributor is registered as a broker-dealer under the Securities Exchange Act of 1934 and each state's securities laws and is a member of the Financial Industry Regulatory Authority ("FINRA"). The offering of the Funds' shares is continuous. The Distribution Agreement provides that the Distributor, as agent in connection with the distribution of Fund shares, will use its best efforts to distribute the Funds' shares. As compensation for its services under the Distribution Agreement, the Distributor may retain all or a portion of the Rule 12b-1 fees payable under the Distribution and Shareholder Servicing Plan, discussed below.

### **DISTRIBUTION PLAN**

The Board, including a majority of the Independent Directors, adopted a Distribution and Shareholder Servicing Plan (the "Plan") for the Funds pursuant to Rule 12b-1 under the 1940 Act. The Plan authorizes payments by a Fund in connection with the distribution of Investor Class shares at an annual rate of 0.25% of the Fund's average daily NAV. Payments may be made by a Fund under the Plan for the purpose of financing any activity primarily intended to result in the sale of shares of the Fund, as determined by the Board. Such activities typically include advertising; compensation for sales and sales marketing activities of financial service agents and others, such as dealers or distributors; shareholder account servicing; and production and dissemination of prospectuses and sales and marketing materials. To the extent any activity is one which a Fund may finance without the Plan, the Fund may also make payments to finance such activity outside of the Plan and not subject to its limitations. The Plan is a "compensation plan" which means that payments under the Plan are based upon a percentage of average daily net assets attributable to the Investor Class regardless of the amounts actually paid or expenses actually incurred by the Distributor; however, in no event, may such payments exceed the maximum allowable fee. It is, therefore, possible that the Distributor may realize a profit in a particular year as a result of these payments. The Plan increases the Investor Class's expenses from what they would otherwise be. A Fund may engage in joint distribution activities with other Baird Funds and to the extent the expenses are not allocated to a specific Baird Fund, expenses will be allocated based on the Fund's net assets.

Administration of the Plan is regulated by Rule 12b-1 under the 1940 Act, which requires that the Board receive and review at least quarterly reports concerning the nature and qualification of expenses which are



made, that the Board, including a majority of the Independent Directors, approve all agreements implementing the Plan and that the Plan may be continued from year-to-year only if the Board, including a majority of the Independent Directors, concludes at least annually that continuation of the Plan is likely to benefit shareholders.

#### Amounts Expensed Under the Plan

To date, no amounts were paid by the Funds pursuant to the Plan.

#### Interests of Certain Persons

With the exception of the Advisor, in its capacity as the Funds' investment advisor and principal underwriter of Fund shares, no "interested person" of a Fund, as defined in the 1940 Act, and no director of the Company has or had a direct or indirect financial interest in the Plan or any related agreement.

#### Anticipated Benefits to the Funds

The continuation of the Plan is approved annually by the Board, including a majority of the directors who are not interested persons (as defined in the 1940 Act) of the Funds and have no direct or indirect financial interest in the Plan or any related agreements. The Board has determined that the Plan is likely to benefit Investor Class shares by providing an incentive for brokers, dealers and other financial intermediaries to engage in sales and marketing efforts on behalf of the Funds and to provide enhanced services to Investor Class shareholders. The Board also determined that the Plan was important to the continued viability of the Investor Class because it is intended to increase assets under management, which in turn should result in certain economies of scale.

#### Shareholder Servicing and Revenue Sharing Payments

The Distributor, out of its own resources and without additional cost to the Funds or their shareholders, may provide additional cash payments or other compensation to broker-dealers and other financial intermediaries who market and sell shares of the Funds and/or who provide various administrative, sub-accounting and shareholder services. These payments, are in addition to the 12b-1 fees payable out of Fund assets to firms that sell Investor Class shares. The payments may specifically be made in connection with the inclusion of the Funds in certain programs offered by broker-dealers or other financial intermediaries, invitations to conferences and seminars held or sponsored by those firms, access to branch offices and sales representatives of those firms and opportunities to make presentations and provide information to them. Payments may be structured as a flat fee, a percentage of net sales or net assets (or a combination thereof) or a fee based on the number of underlying client accounts. The Distributor currently has agreements with the following firms, under which the Distributor makes ongoing payments in lieu of, or in addition to, the 12b-1 fee: Benefit Plans Administrators (BPA), BMO Harris Bank, BNY Mellon, Charles Schwab, Edward Jones & Co., Fidelity (National Financial), Great West Life, J.P. Morgan Retirement Plan Services, LPL Financial, Morgan Stanley Smith Barney, Merrill Lynch (Financial Data Services), Morningstar Investment Services, Pershing, Prudential, Raymond James, TIAA-CREF, UBS, U.S. Bank National Association, Vanguard and Wells Fargo.

The Advisor may also pay cash or non-cash compensation to sales representatives of broker-dealers and other financial intermediaries in the form of occasional gift, meals and entertainment, and pay for exhibit space or sponsorships at regional or national events of broker-dealers and other financial intermediaries.

### Referral Program

As indicated in the Prospectus, the Distributor has a referral program under which it may pay compensation to registered representatives of the Distributor for their efforts in selling Institutional Class shares of the Funds. Such compensation will not exceed 0.0625% per year of the value of the Institutional Class share accounts for which the registered representative is responsible.

The prospect of receiving, or the receipt of additional payments or other compensation as described above may provide the Distributor's registered representatives with an incentive to favor sales of shares of the Funds and other mutual funds whose affiliates offer similar compensation over the sale of shares of mutual funds that do not make such payments.

### **PORTFOLIO HOLDINGS DISCLOSURE POLICY**

The Funds do not provide or permit others to provide information about the Funds' portfolio holdings to any third party on a selective basis, except as permitted by the Company's policy regarding disclosure of portfolio holdings (the "Disclosure Policy"). Pursuant to the Disclosure Policy, the Company may disclose information about the Funds' portfolio holdings only in the following circumstances.

- Each Fund discloses its portfolio holdings by mailing its annual and semi-annual reports to shareholders approximately two months after the end of the fiscal year and six-month period. In addition, the Company discloses the portfolio holdings of each Fund as of the end of the first and third fiscal quarters by filing Form N-Q with the SEC and as of the end of the second and fourth fiscal quarters by filing Form N-CSR with the SEC within 10 calendar days after mailing its annual and semi-annual reports to shareholders.
- Unless a Fund has a valid business reason for not doing so, the Funds' full portfolio holdings as of month-end are posted on the Company's website within 15 calendar days after month-end. The monthly holdings information will remain posted until the holdings information for the following month is posted. A Fund may elect to not post its portfolio holdings on the Company's website as described above if the Fund has a valid business reason for doing so.
- The Funds may also provide portfolio holdings information to various ratings agencies, consultants, broker-dealers, investment advisers, financial intermediaries, investors and others, upon request, so long as such information, at the time it is provided, is posted on the Company's website or otherwise publicly available.

In limited circumstances, for the business purposes described below, the Funds' portfolio holdings may be disclosed to, or known by, certain third parties in advance of their publication on the Company's website.

- The Advisor may disclose Fund portfolio holdings to the Funds' service providers (administrator, fund accountant, custodian, transfer agent and independent pricing service) in connection with the fulfillment of their duties to the Funds. These service providers are required by contract with the Funds to keep such information confidential and not use it for any purpose other than the purpose for which the information was disclosed.
- The Advisor may disclose Fund portfolio holdings to persons who owe a fiduciary duty or other duty of trust or confidence to the Funds, such as the Funds' legal counsel and independent registered public accounting firm.

- Disclosure of portfolio holdings as of a particular date may be made in response to inquiries from consultants, prospective clients or other persons, provided that the recipient signs a confidentiality agreement prohibiting disclosure and misuse of the holdings information.

The Company is prohibited from entering into any other arrangements with third parties to disclose information regarding the Funds' portfolio securities without (1) prior approval of the Advisor's legal and compliance departments; and (2) the execution of a confidentiality agreement by the third parties. No compensation or other consideration may be received by the Funds or the Advisor in connection with the disclosure of portfolio holdings in accordance with this policy.

The Board has delegated to the CCO the responsibility to monitor the foregoing policy and to address any violations thereof. The CCO reports to the Board and the Board reviews any disclosures of Fund portfolio holdings outside of the permitted disclosures described above on a quarterly basis to ensure that disclosure of information about portfolio holdings is in the best interest of Fund shareholders and to address any conflicts between the interests of Fund shareholders and those of the Advisor or any other Fund affiliate.

### **ANTI-MONEY LAUNDERING PROGRAM**

The Company has established an Anti-Money Laundering Compliance Program (the "Program") as required by the Uniting and Strengthening America by Providing Appropriate Tools Required to Intercept and Obstruct Terrorism Act of 2001 ("USA PATRIOT Act"). In order to ensure compliance with this law, the Program provides for the development of internal practices, procedures and controls, the designation of an anti-money laundering compliance officer, an ongoing training program, an independent audit function to determine the effectiveness of the Program and a customer identification program. Mr. Edgar L. Sturkey has been designated as the Company's anti-money laundering compliance officer.

Procedures to implement the Program include, but are not limited to, determining that the Funds' Distributor and transfer agent have established proper anti-money laundering procedures that require the reporting of suspicious and/or fraudulent activity, verifying the identity of the new shareholders, checking shareholder names against designated government lists, including the Office of Foreign Asset Control ("OFAC"), and undertaking a complete and thorough review of all new account applications. The Company will not transact business with any person or entity whose identity cannot be adequately verified.

Pursuant to the USA PATRIOT Act and the Program, a Fund may be required to "freeze" the account of a shareholder if the shareholder appears to be involved in suspicious activity or if certain account information matches information on government lists of known terrorists or other suspicious persons, or a Fund may be required to transfer the account or proceeds of the account to a governmental agency.

### **INDEPENDENT REGISTERED PUBLIC ACCOUNTING FIRM AND FINANCIAL STATEMENTS**

Grant Thornton LLP has been selected as independent registered public accounting firm of the Funds. As such, it is responsible for auditing the financial statements of the Funds.

### **COUNSEL**

Godfrey & Kahn, S.C., 780 North Water Street, Milwaukee, Wisconsin 53202, serves as counsel to the Company and has passed upon the legality of the shares offered by the Funds.

## **PERFORMANCE**

From time to time, the yield and total return of Investor Class shares and Institutional Class shares of a Fund may be quoted in advertisements, shareholder reports or other communications to shareholders. Performance information is generally available by calling the Funds (toll-free) at 1-866-44BAIRD.

## **APPENDIX A - RATINGS DEFINITIONS**

### **Standard & Poor's Issue Credit Rating Definitions**

A Standard & Poor's issue credit rating is a forward-looking opinion about the creditworthiness of an obligor with respect to a specific financial obligation, a specific class of financial obligations, or a specific financial program (including ratings on medium-term note programs and commercial paper programs). It takes into consideration the creditworthiness of guarantors, insurers, or other forms of credit enhancement on the obligation and takes into account the currency in which the obligation is denominated. The opinion reflects Standard & Poor's view of the obligor's capacity and willingness to meet its financial commitments as they come due, and may assess terms, such as collateral security and subordination, which could affect ultimate payment in the event of default.

Issue credit ratings can be either long term or short term. Short-term ratings are generally assigned to those obligations considered short-term in the relevant market. In the U.S., for example, that means obligations with an original maturity of no more than 365 days—including commercial paper. Short-term ratings are also used to indicate the creditworthiness of an obligor with respect to put features on long-term obligations. Medium-term notes are assigned long-term ratings.

#### **Short-Term Issue Credit Ratings**

##### **A-1**

A short-term obligation rated 'A-1' is rated in the highest category by Standard & Poor's. The obligor's capacity to meet its financial commitment on the obligation is strong. Within this category, certain obligations are designated with a plus sign (+). This indicates that the obligor's capacity to meet its financial commitment on these obligations is extremely strong.

##### **A-2**

A short-term obligation rated 'A-2' is somewhat more susceptible to the adverse effects of changes in circumstances and economic conditions than obligations in higher rating categories. However, the obligor's capacity to meet its financial commitment on the obligation is satisfactory.

##### **A-3**

A short-term obligation rated 'A-3' exhibits adequate protection parameters. However, adverse economic conditions or changing circumstances are more likely to lead to a weakened capacity of the obligor to meet its financial commitment on the obligation.

##### **B**

A short-term obligation rated 'B' is regarded as vulnerable and has significant speculative characteristics. The obligor currently has the capacity to meet its financial commitments; however, it faces major ongoing uncertainties which could lead to the obligor's inadequate capacity to meet its financial commitments.

##### **C**

A short-term obligation rated 'C' is currently vulnerable to nonpayment and is dependent upon favorable business, financial, and economic conditions for the obligor to meet its financial commitment on the obligation.

## **D**

A short-term obligation rated 'D' is in default or in breach of an imputed promise. For non-hybrid capital instruments, the 'D' rating category is used when payments on an obligation are not made on the date due, unless Standard & Poor's believes that such payments will be made within any stated grace period. However, any stated grace period longer than five business days will be treated as five business days. The 'D' rating also will be used upon the filing of a bankruptcy petition or the taking of a similar action and where default on an obligation is a virtual certainty, for example due to automatic stay provisions. An obligation's rating is lowered to 'D' if it is subject to a distressed exchange offer.

### **SPUR (Standard & Poor's Underlying Rating)**

A SPUR rating is an opinion about the stand-alone capacity of an obligor to pay debt service on a credit-enhanced debt issue, without giving effect to the enhancement that applies to it. These ratings are published only at the request of the debt issuer/obligor with the designation SPUR to distinguish them from the credit-enhanced rating that applies to the debt issue. Standard & Poor's maintains surveillance of an issue with a published SPUR

### **Dual Ratings**

Dual ratings may be assigned to debt issues that have a put option or demand feature. The first component of the rating addresses the likelihood of repayment of principal and interest as due, and the second component of the rating addresses only the demand feature. The first component of the rating can relate to either a short-term or long-term transaction and accordingly use either short-term or long-term rating symbols. The second component of the rating relates to the put option and is assigned a short-term rating symbol (for example, 'AAA/A-1+' or 'A-1+/A-1'). With U.S. municipal short-term demand debt, the U.S. municipal short-term note rating symbols are used for the first component of the rating (for example, 'SP-1+/A-1+').

The analyses, including ratings, of Standard & Poor's and its affiliates (together Standard & Poor's) are statements of opinion as of the date they are expressed and not statements of fact or recommendations to purchase, hold, or sell any securities or make any investment decisions. Standard & Poor's assumes no obligation to update any information following publication. Users of ratings or other analyses should not rely on them in making any investment decision. Standard & Poor's opinions and analyses do not address the suitability of any security. Standard & Poor's does not act as a fiduciary or an investment advisor except where registered as such. While Standard & Poor's has obtained information from sources it believes to be reliable, Standard & Poor's does not perform an audit and undertakes no duty of due diligence or independent verification of any information it receives. Ratings and other opinions may be changed, suspended, or withdrawn at any time.

### **Active Qualifiers (Currently applied and/or outstanding)**

---

Standard & Poor's assigns qualifiers to ratings when appropriate. This section details active qualifiers.

Standard & Poor's uses five qualifiers that limit the scope of a rating. The structure of the transaction can require the use of a qualifier such as a 'p' qualifier, which indicates the rating addressed the principal portion of the obligation only. Likewise, the qualifier can indicate a limitation on the type of information used, such as "pi" for public information. A qualifier appears as a suffix and is part of the rating.

#### **1. Federal Deposit Insurance Limit: "L" qualifier**

Ratings qualified with 'L' apply only to amounts invested up to federal deposit insurance limits.

## **2. Principal Payment: “p” qualifier**

This suffix is used for issues in which the credit factors, the terms, or both, that determine the likelihood of receipt of payment of principal are different from the credit factors, terms or both that determine the likelihood of receipt of interest on the obligation. The ‘p’ suffix indicates that the rating addresses the principal portion of the obligation only and that the interest portion is not rated.

## **3. Public Information Ratings: “pi” qualifier**

Ratings with a ‘pi’ suffix are based on an analysis of an issuer’s published financial information, as well as additional information in the public domain. They do not, however, reflect in-depth meetings with an issuer’s management and therefore may be based on less comprehensive information than ratings without a ‘pi’ suffix. Ratings with a ‘pi’ suffix are reviewed annually based on a new year’s financial statements, but may be reviewed on an interim basis if a major event occurs that may affect the issuer’s credit quality.

## **4. Preliminary Ratings: “prelim” qualifier**

Preliminary ratings, with the ‘prelim’ suffix, may be assigned to obligors or obligations, including financial programs, in the circumstances described below. Assignment of a final rating is conditional on the receipt by Standard & Poor’s of appropriate documentation. Standard & Poor’s reserves the right not to issue a final rating. Moreover, if a final rating is issued, it may differ from the preliminary rating.

- Preliminary ratings may be assigned to obligations, most commonly structured and project finance issues, pending receipt of final documentation and legal opinions.
- Preliminary ratings are assigned to Rule 415 Shelf Registrations. As specific issues, with defined terms, are offered from the master registration, a final rating may be assigned to them in accordance with Standard & Poor’s policies
- Preliminary ratings may be assigned to obligations that will likely be issued upon the obligor’s emergence from bankruptcy or similar reorganization, based on late-stage reorganization plans, documentation and discussions with the obligor. Preliminary ratings may also be assigned to the obligors. These ratings consider the anticipated general credit quality of the reorganized or postbankruptcy issuer as well as attributes of the anticipated obligation(s).
- Preliminary ratings may be assigned to entities that are being formed or that are in the process of being independently established when, in Standard & Poor’s opinion, documentation is close to final. Preliminary ratings may also be assigned to obligations of these entities’.
- Preliminary ratings may be assigned when a previously unrated entity is undergoing a well-formulated restructuring, recapitalization, significant financing or other transformative event, generally at the point that investor or lender commitments are invited. The preliminary rating may be assigned to the entity and to its proposed obligation(s). These preliminary ratings consider the anticipated general credit quality of the obligor, as well as attributes of the anticipated obligation(s), assuming successful completion of the transformative event. Should the transformative event not occur, Standard & Poor’s would likely withdraw these preliminary ratings.
- A preliminary recovery rating may be assigned to an obligation that has a preliminary issue credit rating.

## **5. Termination Structures: “t” qualifier**

This symbol indicates termination structures that are designed to honor their contracts to full maturity or, should certain events occur, to terminate and cash settle all their contracts before their final maturity date.

## **Inactive Qualifiers**

---

Inactive qualifiers are no longer applied or outstanding.

### **1. Contingent upon final documentation: “\*” inactive qualifier**

This symbol indicated that the rating was contingent upon Standard & Poor’s receipt of an executed copy of the escrow agreement or closing documentation confirming investments and cash flows. Discontinued use in August 1998.

### **2. Termination of obligation to tender: “c” inactive qualifier**

This qualifier was used to provide additional information to investors that the bank may terminate its obligation to purchase tendered bonds if the long-term credit rating of the issuer is below an investment-grade level and/or the issuer’s bonds are deemed taxable. Discontinued use in January 2001.

### **3. U.S. direct government securities: “G” inactive qualifier**

The letter “G” following the rating symbol when a fund’s portfolio consists primarily of direct U.S. Government securities.

### **4. Provisional Ratings: “pr” inactive qualifier**

The letters ‘pr’ indicate that the rating was provisional. A provisional rating assumed the successful completion of the project financed by the debt being rated and indicates that payment of debt service requirements is largely or entirely dependent upon the successful, timely completion of the project. This rating, however, while addressing credit quality subsequent to completion of the project, made no comment on the likelihood of or the risk of default upon failure of such completion.

### **5. Quantitative Analysis of publication information: “q” inactive qualifier**

A ‘q’ subscript indicates that the rating is based solely on quantitative analysis of publicly available information. Discontinued use in April 2001.

### **6. Extraordinary risks: “r” inactive qualifier**

The ‘r’ modifier was assigned to securities containing extraordinary risks, particularly market risks, that are not covered in the credit rating. The absence of an ‘r’ modifier should not be taken as an indication that an obligation will not exhibit extraordinary non-credit related risks. Standard & Poor’s discontinued the use of the ‘r’ modifier for most obligations in June 2000 and for the balance of obligations (mainly structured finance transactions) in November 2002.

## **Active Identifiers**

### **1. Unsolicited: 'unsolicited' and 'u' identifier**

The 'u' identifier and 'unsolicited' designation are unsolicited credit ratings assigned at the initiative of Standard & Poor's and not at the request of the issuer or its agents.

### **2. Structured finance: “sf” identifier**

The 'sf' identifier shall be assigned to ratings on "structured finance instruments" when required to comply with applicable law or regulatory requirement or when Standard & Poor's believes it appropriate. The addition of the 'sf' identifier to a rating does not change that rating's definition or our opinion about the issue's creditworthiness.



## **Local Currency and Foreign Currency Ratings**

Standard & Poor's issuer credit ratings make a distinction between foreign currency ratings and local currency ratings. An issuer's foreign currency rating will differ from its local currency rating when the obligor has a different capacity to meet its obligations denominated in its local currency, vs. obligations denominated in a foreign currency.

## Moody's Credit Rating Definitions

### **Purpose**

The system of rating securities was originated by John Moody in 1909. The purpose of Moody's ratings is to provide investors with a simple system of gradation by which future relative creditworthiness of securities may be gauged.

### **Rating Symbols**

Gradations of creditworthiness are indicated by rating symbols, with each symbol representing a group in which the credit characteristics are broadly the same. There are nine symbols as shown below, from that used to designate least credit risk to that denoting greatest credit risk:

### **Aaa Aa A Baa Ba B Caa Ca C**

Moody's appends numerical modifiers 1, 2, and 3 to each generic rating classification from Aa through Caa.

### **Absence of a Rating**

Where no rating has been assigned or where a rating has been withdrawn, it may be for reasons unrelated to the creditworthiness of the issue.

Should no rating be assigned, the reason may be one of the following:

1. An application was not received or accepted.
2. The issue or issuer belongs to a group of securities or entities that are not rated as a matter of policy.
3. There is a lack of essential data pertaining to the issue or issuer.
4. The issue was privately placed, in which case the rating is not published in Moody's publications.

Withdrawal may occur if new and material circumstances arise, the effects of which preclude satisfactory analysis; if there is no longer available reasonable up-to-date data to permit a judgment to be formed; if a bond is called for redemption; or for other reasons.

### **Changes in Rating**

The credit quality of most issuers and their obligations is not fixed and steady over a period of time, but tends to undergo change. For this reason changes in ratings occur so as to reflect variations in the intrinsic relative position of issuers and their obligations.

A change in rating may thus occur at any time in the case of an individual issue. Such rating change should serve notice that Moody's observes some alteration in creditworthiness, or that the previous rating did not fully reflect the quality of the bond as now seen. While because of their very nature, changes are to be expected more frequently among bonds of lower ratings than among bonds of higher ratings. Nevertheless, the user of bond ratings should keep close and constant check on all ratings — both high and low — to be able to note promptly any signs of change in status that may occur.

### **Limitations to Uses of Ratings\***

Obligations carrying the same rating are not claimed to be of absolutely equal credit quality. In a broad sense, they are alike in position, but since there are a limited number of rating classes used in grading thousands of bonds, the symbols cannot reflect the same shadings of risk which actually exist.

As ratings are designed exclusively for the purpose of grading obligations according to their credit quality, they should not be used alone as a basis for investment operations. For example, they have no value in forecasting the direction of future trends of market price. Market price movements in bonds are influenced not only by the credit quality of individual issues but also by changes in money rates and general economic trends, as well as by the length of maturity, etc. During its life even the highest rated bond may have wide price movements, while its high rating status remains unchanged.

The matter of market price has no bearing whatsoever on the determination of ratings, which are not to be construed as recommendations with respect to “attractiveness”. The attractiveness of a given bond may depend on its yield, its maturity date or other factors for which the investor may search, as well as on its credit quality, the only characteristic to which the rating refers.

Since ratings involve judgments about the future, on the one hand, and since they are used by investors as a means of protection, on the other, the effort is made when assigning ratings to look at “worst” possibilities in the “visible” future, rather than solely at the past record and the status of the present. Therefore, investors using the rating should not expect to find in them a reflection of statistical factors alone, since they are an appraisal of long-term risks, including the recognition of many non-statistical factors.

Though ratings may be used by the banking authorities to classify bonds in their bank examination procedure, Moody’s ratings are not made with these bank regulations in mind. Moody’s Investors Service’s own judgment as to the desirability or non-desirability of a bond for bank investment purposes is not indicated by Moody’s ratings.

Moody’s ratings represent the opinion of Moody’s Investors Service as to the relative creditworthiness of securities. As such, they should be used in conjunction with the descriptions and statistics appearing in Moody’s publications. Reference should be made to these statements for information regarding the issuer. Moody’s ratings are not commercial credit ratings. In no case is default or receivership to be imputed unless expressly stated.

\*As set forth more fully on the copyright, credit ratings are, and must be construed solely as, statements of opinion and not statements of fact or recommendations to purchase, sell or hold any securities. Each rating or other opinion must be weighed solely as one factor in any investment decision made by or on behalf of any user of the information, and each such user must accordingly make its own study and evaluation of each security and of each issuer and guarantor of, and each provider of credit support for, each security that it may consider purchasing, selling or holding.

### **Short-Term Obligation Ratings**

Moody’s assigns ratings to long-term and short-term financial obligations. Long-term ratings are assigned to issuers or obligations with an original maturity of one year or more and reflect both on the likelihood of a default on contractually promised payments and the expected financial loss suffered in the event of default. Short-term ratings are assigned to obligations with an original maturity of thirteen months or less and reflect the likelihood of a default on contractually promised payments.

Moody’s employs the following designations to indicate the relative repayment ability of rated issuers:

#### **P-1**

Issuers (or supporting institutions) rated Prime-1 have a superior ability to repay short-term debt obligations.

**P-2**

Issuers (or supporting institutions) rated Prime-2 have a strong ability to repay short-term debt obligations.

**P-3**

Issuers (or supporting institutions) rated Prime-3 have an acceptable ability to repay short-term debt obligations.

**NP**

Issuers (or supporting institutions) rated Not Prime do not fall within any of the Prime rating categories.

The following table indicates the long-term ratings consistent with different short-term ratings when such long-term ratings exist.

**SHORT-TERM VS. LONG-TERM RATINGS**

LONG-TERM RATING	SHORT-TERM CP
Aaa Aa1 Aa2 Aa3 A1 A2 A3	Prime-1
Baa1 Baa2 Baa3	
Ba1, Ba2, Ba3 B1, B2, B3 Caa1, Caa2, Caa3 Ca, C	Not Prime

## **Fitch's National Credit Ratings**

For those countries in which foreign and local currency sovereign ratings are below 'AAA', and where there is demand for such ratings, Fitch Ratings will provide National Ratings. It is important to note that each National Rating scale is unique and is defined to serve the needs of the local market in question.

The National Rating scale provides a relative measure of creditworthiness for rated entities only within the country concerned. Under this rating scale, a 'AAA' Long-Term National Rating will be assigned to the lowest relative risk within that country, which, in most but not all cases, will be the sovereign state.

The National Rating scale merely ranks the degree of perceived risk relative to the lowest default risk in that same country. Like local currency ratings, National Ratings exclude the effects of sovereign and transfer risk and exclude the possibility that investors may be unable to repatriate any due interest and principal repayments. It is not related to the rating scale of any other national market. Comparisons between different national scales or between an individual national scale and the international rating scale are therefore inappropriate and potentially misleading. Consequently they are identified by the addition of a special identifier for the country concerned, such as 'AAA(arg)' for National Ratings in Argentina.

In certain countries, regulators have established credit rating scales, to be used within their domestic markets, using specific nomenclature. In these countries, the agency's National Rating definitions may be substituted by the regulatory scales. For instance, Fitch's National Short Term Ratings of 'F1+(xxx)', 'F1(xxx)', 'F2(xxx)' and 'F3(xxx)' may be substituted by the regulatory scales, e.g. 'A1+', 'A1', 'A2' and 'A3'. The below definitions thus serve as a template, but users should consult the individual scales for each country listed on Fitch's regional websites to determine if any additional or alternative category definitions apply.

### **Limitations of the National Rating Scale**

Specific limitations relevant to National Rating scale include:

- National scale ratings are only available in selected countries.
- National scale ratings are only directly comparable with other national ratings in the same country. There is a certain correlation between national and global ratings but there is not a precise translation between the scales. The implied probability of default of a given national scale rating will vary over time.
- The value of default studies for national ratings can be limited. Due to the relative nature of national scales, a given national scale rating is not intended to represent a fixed amount of default risk over time. As a result, a default study using only national ratings may not give an accurate picture of the historical relationship between ratings and default risk. Users should exercise caution if they wish to infer future default probabilities for national scale ratings using the historical default experience with international ratings and mapping tables to link the national and international ratings. As with ratings on any scale, the future will not necessarily follow the past.
- Fitch attaches less confidence to conclusions about national scale default probabilities than for International Credit ratings. There has not been a comprehensive global study of default history among entities with national scales to show that their ex-post default experience has been consistent with ex-ante probabilities implied. This is due to the relatively short history of ratings in emerging markets and the restrictive relative nature of the national scales.

The above list is not exhaustive, and is provided for the reader's convenience. Readers are requested to review the section Understanding Credit Ratings — Limitations and Usage for further information on the limitations of the agency's ratings.

### **National Short-Term Credit Ratings**

#### **F1(xxx)**

Indicates the strongest capacity for timely payment of financial commitments relative to other issuers or obligations in the same country. Under the agency's National Rating scale, this rating is assigned to the lowest default risk relative to others in the same country. Where the liquidity profile is particularly strong, a "+" is added to the assigned rating.

#### **F2(xxx)**

Indicates a good capacity for timely payment of financial commitments relative to other issuers or obligations in the same country. However, the margin of safety is not as great as in the case of the higher ratings.

#### **F3(xxx)**

Indicates an adequate capacity for timely payment of financial commitments relative to other issuers or obligations in the same country. However, such capacity is more susceptible to near-term adverse changes than for financial commitments in higher rated categories.

#### **B(xxx)**

Indicates an uncertain capacity for timely payment of financial commitments relative to other issuers or obligations in the same country. Such capacity is highly susceptible to near-term adverse changes in financial and economic conditions.

#### **C(xxx)**

Indicates a highly uncertain capacity for timely payment of financial commitments relative to other issuers or obligations in the same country. Capacity for meeting financial commitments is solely reliant upon a sustained, favorable business and economic environment.

#### **RD: Restricted default**

Indicates an entity that has defaulted on one or more of its financial commitments, although it continues to meet other financial obligations. Applicable to entity ratings only.

#### **D(xxx)**

Indicates actual or imminent payment default.

### **Notes to Long-Term and Short-Term National Ratings:**

The ISO international country code is placed in parentheses immediately following the rating letters to indicate the identity of the National market within which the rating applies. For illustrative purposes, (xxx) has been used.

"+" or "-" may be appended to a National Rating to denote relative status within a major rating category. Such suffixes are not added to the 'AAA(xxx)' Long-Term National Rating category, to categories below 'CCC(xxx)', or to Short-Term National Ratings other than 'F1(xxx)'.

## LONG-TERM RATINGS

### Standard & Poor's Long-Term Issue Credit Ratings

Issue credit ratings are based, in varying degrees, on Standard & Poor's analysis of the following considerations:

- Likelihood of payment—capacity and willingness of the obligor to meet its financial commitment on an obligation in accordance with the terms of the obligation;
- Nature of and provisions of the obligation and the promise we impute.
- Protection afforded by, and relative position of, the obligation in the event of bankruptcy, reorganization, or other arrangement under the laws of bankruptcy and other laws affecting creditors' rights.

Issue ratings are an assessment of default risk, but may incorporate an assessment of relative seniority or ultimate recovery in the event of default. Junior obligations are typically rated lower than senior obligations, to reflect the lower priority in bankruptcy, as noted above. (Such differentiation may apply when an entity has both senior and subordinated obligations, secured and unsecured obligations, or operating company and holding company obligations.)

### **Long-Term Issue Credit Ratings**

#### **AAA**

An obligation rated 'AAA' has the highest rating assigned by Standard & Poor's. The obligor's capacity to meet its financial commitment on the obligation is extremely strong.

#### **AA**

An obligation rated 'AA' differs from the highest-rated obligations only to a small degree. The obligor's capacity to meet its financial commitment on the obligation is very strong.

#### **A**

An obligation rated 'A' is somewhat more susceptible to the adverse effects of changes in circumstances and economic conditions than obligations in higher-rated categories. However, the obligor's capacity to meet its financial commitment on the obligation is still strong.

#### **BBB**

An obligation rated 'BBB' exhibits adequate protection parameters. However, adverse economic conditions or changing circumstances are more likely to lead to a weakened capacity of the obligor to meet its financial commitment on the obligation.

#### **BB; B; CCC; CC; and C**

Obligations rated 'BB', 'B', 'CCC', 'CC', and 'C' are regarded as having significant speculative characteristics. 'BB' indicates the least degree of speculation and 'C' the highest. While such obligations will likely have some quality and protective characteristics, these may be outweighed by large uncertainties or major exposures to adverse conditions.

**BB**

An obligation rated 'BB' is less vulnerable to nonpayment than other speculative issues. However, it faces major ongoing uncertainties or exposure to adverse business, financial, or economic conditions which could lead to the obligor's inadequate capacity to meet its financial commitment on the obligation.

**B**

An obligation rated 'B' is more vulnerable to nonpayment than obligations rated 'BB', but the obligor currently has the capacity to meet its financial commitment on the obligation. Adverse business, financial, or economic conditions will likely impair the obligor's capacity or willingness to meet its financial commitment on the obligation.

**CCC**

An obligation rated 'CCC' is currently vulnerable to nonpayment, and is dependent upon favorable business, financial, and economic conditions for the obligor to meet its financial commitment on the obligation. In the event of adverse business, financial, or economic conditions, the obligor is not likely to have the capacity to meet its financial commitment on the obligation.

**CC**

An obligation rated 'CC' is currently highly vulnerable to nonpayment. The 'CC' rating is used when a default has not yet occurred, but Standard & Poor's expects default to be a virtual certainty, regardless of the anticipated time to default.

**C**

An obligation rated 'C' is currently highly vulnerable to nonpayment, and the obligation is expected to have lower relative seniority or lower ultimate recovery compared to obligations that are rated higher.

**D**

An obligation rated 'D' is in default or in breach of an imputed promise. For non-hybrid capital instruments, the 'D' rating category is used when payments on an obligation are not made on the date due, unless Standard & Poor's believes that such payments will be made within five business days in the absence of a stated grace period or within the earlier of the stated grace period or 30 calendar days. The 'D' rating also will be used upon the filing of a bankruptcy petition or the taking of similar action and where default on an obligation is a virtual certainty, for example due to automatic stay provisions. An obligation's rating is lowered to 'D' if it is subject to a distressed exchange offer.

**NR**

This indicates that no rating has been requested, or that there is insufficient information on which to base a rating, or that Standard & Poor's does not rate a particular obligation as a matter of policy.

**Plus (+) or minus (-)**

The ratings from 'AA' to 'CCC' may be modified by the addition of a plus (+) or minus (-) sign to show relative standing within the major rating categories.

*See active and inactive qualifiers following Standard & Poor's Short-Term Issue Credit Ratings beginning on page A-3.*



## Moody's Long-Term Obligation Ratings

### **Long-Term Obligation Ratings**

Moody's assigns ratings to long-term and short-term financial obligations. Long-term ratings are assigned to issuers or obligations with an original maturity of one year or more and reflect both on the likelihood of a default on contractually promised payments and the expected financial loss suffered in the event of default. Short-term ratings are assigned to obligations with an original maturity of thirteen months or less and reflect the likelihood of a default on contractually promised payments.

### **Moody's Long-Term Rating Definitions:**

#### **Aaa**

Obligations rated Aaa are judged to be of the highest quality, subject to the lowest level of credit risk.

#### **Aa**

Obligations rated Aa are judged to be of high quality and are subject to very low credit risk.

#### **A**

Obligations rated A are considered upper-medium grade and are subject to low credit risk.

#### **Baa**

Obligations rated Baa are judged to be medium-grade and subject to moderate credit risk and as such may possess certain speculative characteristics.

#### **Ba**

Obligations rated Ba are judged to be speculative and are subject to substantial credit risk.

#### **B**

Obligations rated B are considered speculative and are subject to high credit risk.

#### **Caa**

Obligations rated Caa are judged to be speculative of poor standing and are subject to very high credit risk.

#### **Ca**

Obligations rated Ca are highly speculative and are likely in, or very near, default, with some prospect of recovery of principal and interest.

#### **C**

Obligations rated C are the lowest rated and are typically in default, with little prospect for recovery of principal or interest.

Note: Moody's appends numerical modifiers 1, 2, and 3 to each generic rating classification from Aaa through Caa. The modifier 1 indicates that the obligation ranks in the higher end of its generic rating category; the modifier 2 indicates a mid-range ranking; and the modifier 3 indicates a ranking in the lower end of that generic rating category. Additionally, a "(hyb)" indicator is appended to all ratings of hybrid securities issued by banks, insurers, finance companies, and securities firms.\*

*\* By their terms, hybrid securities allow for the omission of scheduled dividends, interest, or principal payments, which can potentially result in impairment if such an omission occurs. Hybrid securities may*

*also be subject to contractually allowable write-downs of principal that could result in impairment. Together with the hybrid indicator, the long-term obligation rating assigned to a hybrid security is an expression of the relative credit risk associated with that security.*

## Fitch's National Long-Term Credit Ratings

### **AAA(xxx)**

'AAA' National Ratings denote the highest rating assigned by the agency in its National Rating scale for that country. This rating is assigned to issuers or obligations with the lowest expectation of default risk relative to all other issuers or obligations in the same country.

### **AA(xxx)**

'AA' National Ratings denote expectations of very low default risk relative to other issuers or obligations in the same country. The default risk inherent differs only slightly from that of the country's highest rated issuers or obligations.

### **A(xxx)**

'A' National Ratings denote expectations of low default risk relative to other issuers or obligations in the same country. However, changes in circumstances or economic conditions may affect the capacity for timely repayment to a greater degree than is the case for financial commitments denoted by a higher rated category.

### **BBB(xxx)**

'BBB' National Ratings denote a moderate default risk relative to other issuers or obligations in the same country. However, changes in circumstances or economic conditions are more likely to affect the capacity for timely repayment than is the case for financial commitments denoted by a higher rated category.

### **BB(xxx)**

'BB' National Ratings denote an elevated default risk relative to other issuers or obligations in the same country. Within the context of the country, payment is uncertain to some degree and capacity for timely repayment remains more vulnerable to adverse economic change over time.

### **B(xxx)**

'B' National Ratings denote a significantly elevated default risk relative to other issuers or obligations in the same country. Financial commitments are currently being met but a limited margin of safety remains and capacity for continued timely payments is contingent upon a sustained, favorable business and economic environment. For individual obligations, may indicate distressed or defaulted obligations with potential for extremely high recoveries.

### **CCC(xxx)**

'CCC' National Ratings denote that default is a real possibility. Capacity for meeting financial commitments is solely reliant upon sustained, favorable business or economic conditions.

### **CC(xxx)**

'CC' National Ratings denote that default of some kind appears probable.

### **C(xxx)**

'C' National Ratings denote that default is imminent.

### **RD: Restricted default.**

'RD' ratings indicated that an issuer that in Fitch Ratings' opinion has experienced an uncured payment default on a bond, loan or other material financial obligation but which has not entered into bankruptcy filings, administration, receivership, liquidation or other formal winding-up procedure, and which has not otherwise ceased business. This would include:

- the selective payment default on a specific class or currency of debt;
- the uncured expiry of any applicable grace period, cure period or default forbearance period following a payment default on a bank loan, capital markets security or other material financial obligation;
- the extension of multiple waivers or forbearance periods upon a payment default on one or more material financial obligations either in series or in parallel; or
- execution of a distressed debt exchange on one or more material financial obligations.

**D(xxx)**

‘D’ National Ratings denote an issuer or instrument that is currently in default.

**Notes to Long-Term and Short-Term National Ratings:**

The ISO International country code is placed in parentheses immediately following the rating letters to indicate the identity of the National market within which the rating applies. For illustrative purposes, (xxx) has been used.

“+” or “-” may be appended to a National Rating to denote relative status within a major rating category. Such suffixes are not added to the ‘AAA(xxx)’ Long-Term National Rating category, to categories below ‘CCC(xxx)’, or to Short-Term National Ratings other than ‘F1(xxx)’.

## MUNICIPAL NOTE RATINGS

### **Standard & Poor's Municipal Short-Term Note Ratings Definitions**

A Standard & Poor's U.S. municipal note rating reflects Standard & Poor's opinion about the liquidity factors and market access risks unique to the notes. Notes due in three years or less will likely receive a note rating. Notes with an original maturity of more than three years will most likely receive a long-term debt rating. In determining which type of rating, if any, to assign, Standard & Poor's analysis will review the following considerations:

- Amortization schedule—the larger the final maturity relative to other maturities, the more likely it will be treated as a note; and
- Source of payment—the more dependent the issue is on the market for its refinancing, the more likely it will be treated as a note.

Note rating symbols are as follows:

#### **SP-1**

Strong capacity to pay principal and interest. An issue determined to possess a very strong capacity to pay debt service is given a plus (+) designation.

#### **SP-2**

Satisfactory capacity to pay principal and interest, with some vulnerability to adverse financial and economic changes over the term of the notes.

#### **SP-3**

Speculative capacity to pay principal and interest.

*See active and inactive qualifiers following Standard & Poor's Short-Term Issue Credit Ratings beginning on page A-3.*

### **Moody's US Municipal Short-Term Debt And Demand Obligation Ratings**

#### **Short-Term Obligation Ratings**

While the global short-term 'prime' rating scale is applied to US municipal tax-exempt commercial paper, these programs are typically backed by external letters of credit or liquidity facilities and their short-term prime ratings usually map to the long-term rating of the enhancing bank or financial institution and not to the municipality's rating. Other short-term municipal obligations, which generally have different funding sources for repayment, are rated using two additional short-term rating scales (*i.e.*, the MIG and VMIG scales discussed below).

The Municipal Investment Grade (MIG) scale is used to rate US municipal bond anticipation notes of up to three years maturity. Municipal notes rated on the MIG scale may be secured by either pledged revenues or proceeds of a take-out financing received prior to note maturity. MIG ratings expire at the maturity of the obligation, and the issuer's long-term rating is only one consideration in assigning the MIG rating. MIG ratings are divided into three levels—MIG 1 through MIG 3—while speculative grade short-term obligations are designated SG.

**MIG 1**

This designation denotes superior credit quality. Excellent protection is afforded by established cash flows, highly reliable liquidity support, or demonstrated broad-based access to the market for refinancing.

**MIG 2**

This designation denotes strong credit quality. Margins of protection are ample, although not as large as in the preceding group.

**MIG 3**

This designation denotes acceptable credit quality. Liquidity and cash-flow protection may be narrow, and market access for refinancing is likely to be less well-established.

**SG**

This designation denotes speculative-grade credit quality. Debt instruments in this category may lack sufficient margins of protection.

**Demand Obligation Ratings**

In the case of variable rate demand obligations (VRDOs), a two-component rating is assigned: a long or short-term debt rating and a demand obligation rating. The first element represents Moody's evaluation of risk associated with scheduled principal and interest payments. The second element represents Moody's evaluation of risk associated with the ability to receive purchase price upon demand ("demand feature"). The second element uses a rating from a variation of the MIG scale called the Variable Municipal Investment Grade (VMIG) scale. The rating transitions on the VMIG scale, as shown in the diagram below, differ from those on the Prime scale to reflect the risk that external liquidity support generally will terminate if the issuer's long-term rating drops below investment grade.

**VMIG 1**

This designation denotes superior credit quality. Excellent protection is afforded by the superior short-term credit strength of the liquidity provider and structural and legal protections that ensure the timely payment of purchase price upon demand.

**VMIG 2**

This designation denotes strong credit quality. Good protection is afforded by the strong short-term credit strength of the liquidity provider and structural and legal protections that ensure the timely payment of purchase price upon demand.

**VMIG 3**

This designation denotes acceptable credit quality. Adequate protection is afforded by the satisfactory short-term credit strength of the liquidity provider and structural and legal protections that ensure the timely payment of purchase price upon demand.

**SG**

This designation denotes speculative-grade credit quality. Demand features rated in this category may be supported by a liquidity provider that does not have an investment grade short-term rating or may lack the structural and/or legal protections necessary to ensure the timely payment of purchase price upon demand.

## US MUNICIPAL SHORT-TERM VS. LONG-TERM RATINGS

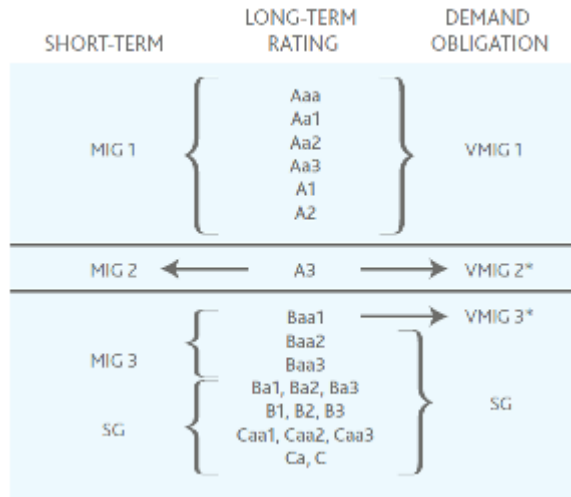

\*For SBPA-backed VRDBS. The rating transitions are higher to allow for distance to downgrade to below-investment grade due to the presence of automatic termination events in the SBPAs

13743543.9